

Module III

2.15. PHASE

Phase of an alternating quantity is the fraction of the time period or cycle that has elapsed since it has last passed from the chosen zero position or origin.

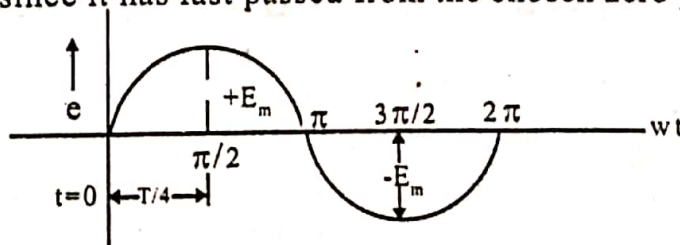

Fig. 2.20

Note that the time is counted from the instant the voltage is zero and becoming positive. The maximum positive value E_m occurs at $T/4$ second or $\pi/2$ radians, or we can say that the phase of maximum positive value is $T/4$ seconds or $\pi/2$ radians.

2.15.1 Phase angle

Phase angle ϕ is equivalent of 'phase' in radian or degree. The phase angle of the max. value of the given sinusoidal voltage is $\pi/2$ radians or 90 degree.

2.15.2 Phase difference

When two alternating quantities of same frequency have different zero points they are said to have a phase difference. Phase difference between two alternating quantities is the fractional part of time period through which one alternating quantity has advanced over another alternating quantity. Two alternating quantities are in phase when both pass through their zero value and also attain their maximum value at the same instant. Two alternating quantities are out of phase if they reach their minimum and maximum values at different times but always have an equal phase angle between them.

2.15.3 Lagging and Leading quantities

The terms lead or lag are used to describe the relative positions in terms of two sinusoidal alternating quantities that are not in phase. The one that is ahead in time is said to lead while the one behind lags.

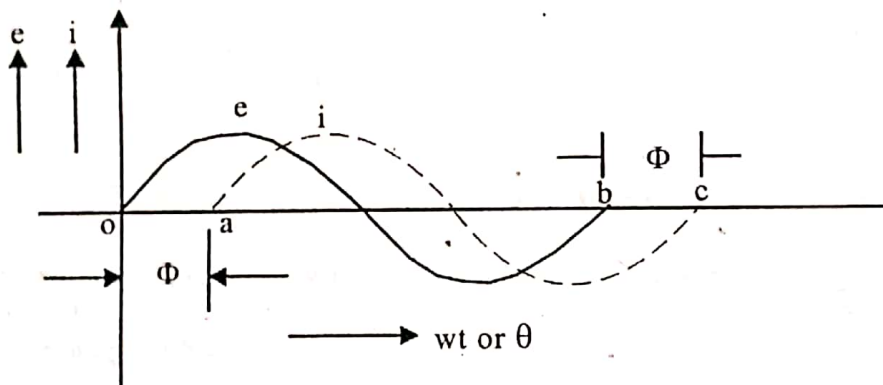

Fig. 2.21.

2.15.4. Lagging and leading wave forms

If the wave forms of two sinusoidal quantities are given, the leading quantity is that which attains its zero or maximum value first. See fig 2.21

$$e = E_m \sin \omega t$$

$$i = I_m \sin (\omega t - \phi)$$

2.16 PHASOR REPRESENTATION OF SINUSOIDAL QUANTITIES

A sinusoidal alternating voltage or current may be represented by a line of definite length rotating in anticlockwise direction at a constant angular velocity (ω). Such a rotating vector is called a phasor. The length of the phasor is taken equal to the maximum value (on suitable scale) of the alternating quantity and equal to angular velocity of the alternating quantity.

Consider an alternating quantity (current) represented by the equation $i = I_m \sin \omega t$. Take a line OP to represent to scale the maximum value I_m . Imagine the line OP or phasor is rotating in anticlockwise direction at an angular velocity of ω rad/sec about

the point O. Measuring the time from the instant when OP is horizontal, let OP rotate through an angle ($\theta = \omega t$) in the anticlockwise direction. The projection of OP on Y axis is OM.

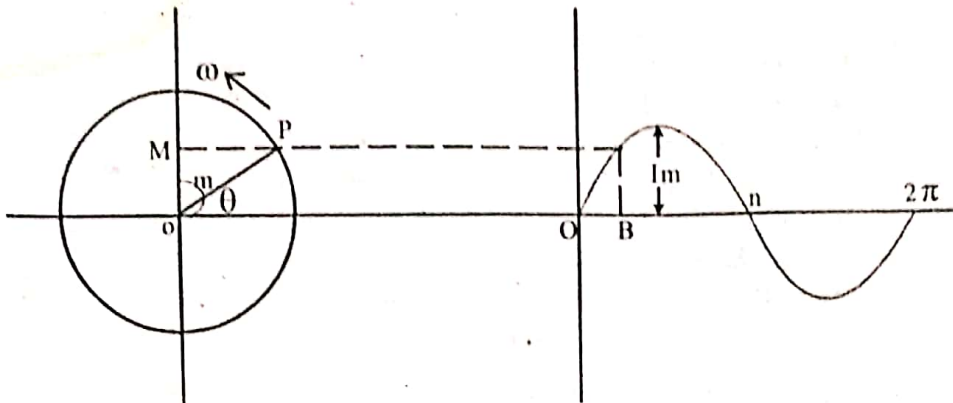

Fig. 2.22

Hence the projection of the phasor OP on Y axis at any instant gives the value of current at that instant. Thus when $\theta = 90^\circ$ the projection on Y axis is $OP = I_m$. If we plot the projections of the phasor on y axis versus its angular position, point by point a sinusoidal alternating current is generated as shown in figure 2.22. Thus the phasor represents the sine wave for every instant of time.

2.16.1 Lagging and leading phasors

Consider a sinusoidal voltage wave e and sinusoidal current i of the same frequency. Suppose the current lags the voltage by an angle ϕ . The two alternating quantities may be represented on the same angular velocity ω and the phase difference ϕ between them remains the same at all times

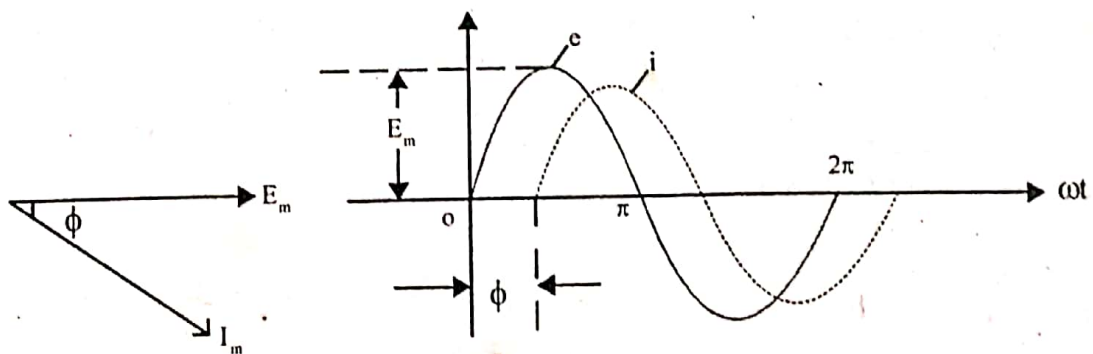

Fig. 2.23

$$e = E_m \sin \omega t$$

$$i = I_m \sin (\omega t - \phi)$$

2.16.2 Addition and Subtraction of Phasors

Alternating voltages and currents are phasors. They are treated in the same manner as forces. Addition or subtraction of alternating voltages or currents may be done by.

1) Parallelogram method

This method is used for the addition of two phasors at a time. The phasors are represented in magnitude and direction by the adjacent sides of a parallelogram. Then the diagonal of the parallelogram represents the maximum value of the resultant.

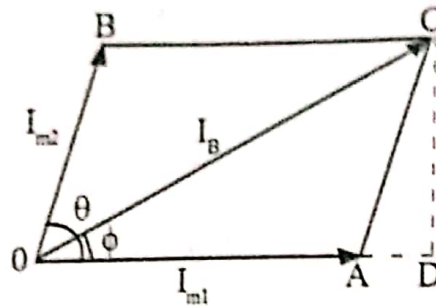

Fig. 2.24

2) Method of Components

This method provides a very convenient means to add two or more phasors. Each phasor is resolved into horizontal and vertical components. The horizontals are summed up algebraically to give the resultant horizontal component X. The verticals are likewise summed up algebraically to give the resultant vertical component Y.

$$\text{Then resultant} = \sqrt{X^2 + Y^2}$$

$$\text{Phase angle of resultant } \tan \phi = Y/X$$

2.17 EXAMPLES

1 Find the resultant of the following four emfs and express the answer in a similar form

$$e_1 = 30 \sin \omega t$$

$$e_2 = 40 \sin (\omega t + \pi/4)$$

$$e_3 = 50 \sin (\omega t - \pi/3)$$

$$e_4 = 20 \sin (\omega t + 3\pi/4)$$

Solution

The angle of lag or lead with respect to X axis is represented below

$$e_1 = 0$$

$$e_2 = \pi/4 = 45^\circ$$

$$e_3 = -(\pi/3) = -60^\circ$$

$$e_4 = 3\pi/4 = 135^\circ$$

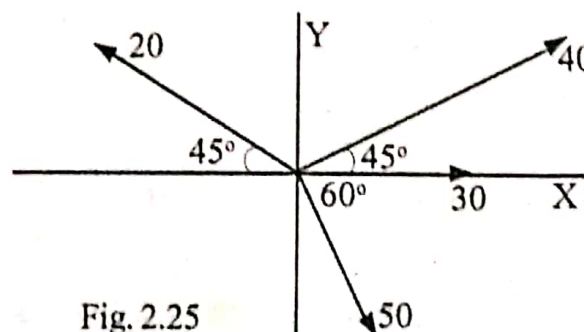

Fig. 2.25

Resolving these components along X axis we get.

$$\begin{aligned} \text{X components} &= 30 + 40 \cos 45^\circ + 50 \cos 60^\circ - 20 \cos 45^\circ \\ &= 30 + 28.28 + 25 - 14.14 = 69.14 \text{ V} \end{aligned}$$

$$\begin{aligned} \text{Y components} &= 0 + 40 \sin 45^\circ - 50 \sin 60^\circ + 20 \sin 45^\circ \\ &= 0 + 28.28 - 43.3 + 14.14 = -0.88 \text{ V} \end{aligned}$$

$$\begin{aligned} E &= \sqrt{X^2 + Y^2} = \sqrt{69.14^2 + 0.88^2} \\ &= 69.15 \text{ V} \end{aligned}$$

$$\begin{aligned} \tan \phi &= -0.88/69.14 = -0.01264 \\ \phi &= \tan^{-1}(-0.01264) = .74^\circ \text{ lagging} \\ &= 0.0132 \text{ rad} \\ e &= 69.15 \sin(\omega t - 0.0132) \end{aligned}$$

2 Two currents represented by

$$i_1 = 15 \sin(\omega t + \pi/3) \text{ and}$$

$i_2 = 25 \sin(\omega t + \pi/4)$ are fed into common conductor. Find an expression for the total current in the same form. If the circuit has a resistance of 2Ω what will be total energy loss in 10 hrs ?

Solution

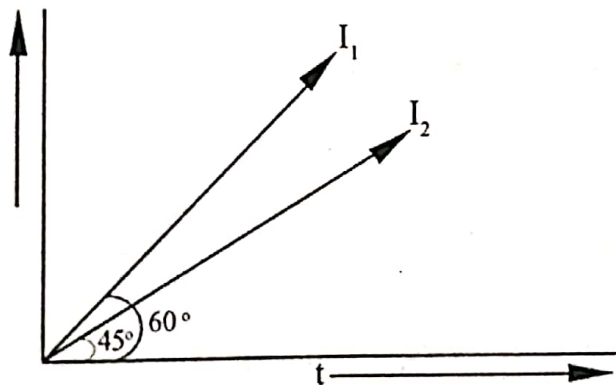

Fig. 2.26

The current phasors are shown in figure

$$\begin{aligned} \text{X components} &= 15 \cos 60^\circ + 25 \cos 45^\circ \\ &= 25.17 \end{aligned}$$

$$\text{Y components} = 15 \sin 60^\circ + 25 \sin 45^\circ = 30.66$$

$$\therefore I_m = \sqrt{25.17^2 + 30.66^2} = 39.6 \text{ A}$$

$$\tan \phi = \frac{30.66}{25.17} = 1.218$$

$$\phi = \tan^{-1} 1.218 = 50.7^\circ = 0.884 \text{ rad}$$

$$\therefore i = 39.6 \sin(\omega t + 0.884)$$

$$I_{\text{rms}} = \frac{I_m}{\sqrt{2}} = \frac{39.6}{\sqrt{2}} = 28\text{A}$$

$$\begin{aligned} \text{Energy loss} &= I^2 R t \\ &= 28^2 \times 2 \times 10 \times 60 \times 60 \\ &= 56.448 \times 10^6 \text{ joules} \end{aligned}$$

2.18 PHASOR DIAGRAM USING RMS VALUE

Instead of drawing the phasor diagram using maximum values it is a common practice to draw it using r.m.s. values. This does not alter the phase difference between the phasors because only the lengths of the phasors are changed. The figures given below show the phasor diagrams using maximum values and also the r.m.s. values.

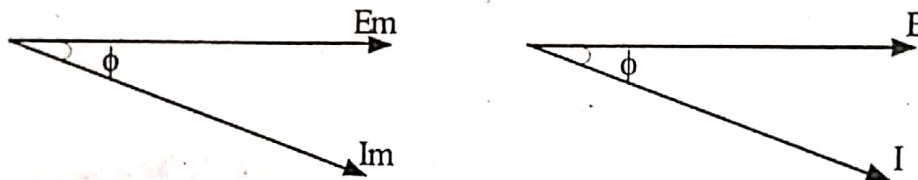

Fig. 2.27

Since r.m.s values are more commonly used in a.c. circuits for calculation we shall use r.m.s. values in all phasor diagrams from now on wards.

2.19 COMPLEX NOTATION

The voltage, current and other parameters in an A.C. circuit may be represented by complex numbers. A complex quantity may be expressed in any of the following forms

1. Rectangular form or complex form

Consider a vector quantity E . This can be expressed as

$E = x \pm jy$ where x and y are real numbers; x is in phase or active component, y is the quadrature or reactive component and $j = \sqrt{-1}$ is an operator which is an imaginary number.

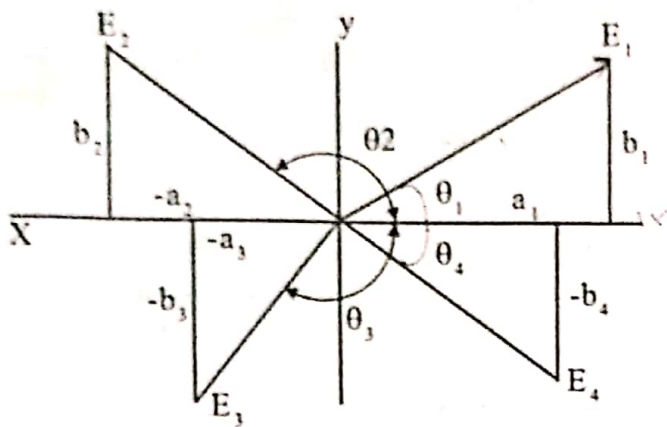

Fig. 2.28(a)

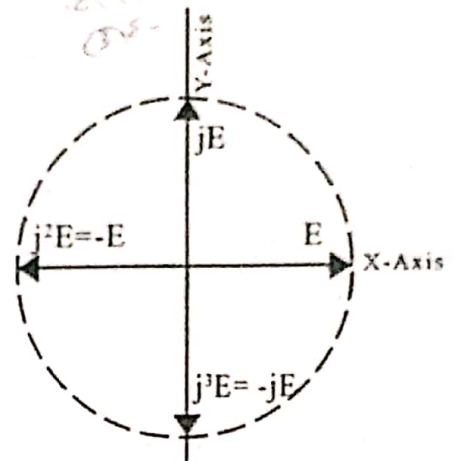

Fig. 2.28(b)

Referring to the figure given

$$E_1 = a_1 + jb_1 ; \quad E_2 = -a_2 + jb_2 ;$$

The use of the operator 'j' indicates that component 'b' is along the j axis or imaginary axis.

The operator j when applied to a phasor E gives the new phasor jE, which is displaced by 90° in anticlockwise direction from E. The double application of j on phasor E rotates it through 180° in counter clock wise direction giving j²E = -E Hence j² = -1 or j = √-1, which is an imaginary number. The magnitude of the phasor is unaffected, while the direction changes.

j is an operator, which rotates the phasor through 90° in counter clockwise direction without changing the magnitude of the phasor

2. Trigonometric form

$$E = r(\text{Cos } \phi \pm j \text{ Sin } \phi)$$

Where $r = \sqrt{x^2 + y^2}$ is called the modulus of E and angle $\phi = \tan^{-1} y/x$ is called the argument of E.

3. Exponential

$$E = re^{j\phi}$$

4. Polar form

$$E = r \angle \pm \phi$$

Let phasor E₁ be equal to E₁ = a₁ + jb₁ This may be expressed in polar form as

$$E_1 = r \angle \phi \text{ where } r = \sqrt{a_1^2 + b_1^2} \text{ and } \phi = \tan^{-1} b_1/a_1 \text{ is its argument.}$$

2.20 OPERATIONS ON COMPLEX NUMBERS

2.20.1 Sum and difference of complex numbers

The sum of two complex numbers is defined as the complex number whose real part is the sum of the real parts of the two complex numbers and whose imaginary part is the sum of the imaginary parts of the two complex numbers. Thus,

$$(a+jb) + (c+jd) = (a+c) + j(b+d)$$

The difference of two complex numbers is another complex number whose real part is the difference of the two real parts and whose imaginary part is the difference of the two imaginary parts of the two complex numbers. Thus,

$$(a+jb) - (c+jd) = (a-c) + j(b-d)$$

2.20.2. Product of complex numbers

a) Rectangular form.

$$\begin{aligned} (a+jb)(c+jd) &= ac + jad + jbc + j^2bd \\ &= (ac-bd) + j(ad+bc) \quad \text{Since } j^2 = -1 \end{aligned}$$

b) Trigonometric form.

$$\begin{aligned} r_1(\cos\phi_1 + j \sin\phi_1) \times r_2(\cos\phi_2 + j \sin\phi_2) \\ = r_1 r_2 (\cos(\phi_1 + \phi_2) + j \sin(\phi_1 + \phi_2)) \end{aligned}$$

c) Exponential form

$$r_1 e^{j\phi_1} \times r_2 e^{j\phi_2} = r_1 r_2 e^{j(\phi_1 + \phi_2)}$$

d) Polar Form

$$r_1 \angle \phi_1 \times r_2 \angle \phi_2 = r_1 r_2 \angle \phi_1 + \phi_2$$

2.20.3. Conjugate of a complex number

The conjugate of a complex number A is defined as whose real part is equal to the real part of A and whose imaginary part is equal to the negative of the imaginary part of A. The conjugate of A is denoted as A*. Thus if $A = a+jb$ $A^* = a-jb$.

From the figure it is

observed that A* is the mirror image of A.

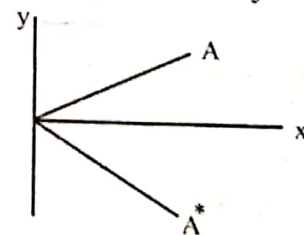

Figure 2.29

2.20.4. Division of complex numbers

a) Rectangular form

$$\frac{(a+jb)}{(c+jd)} = \frac{(a+jb)(c-jd)}{(c+jd)(c-jd)} = \frac{ac-jad+jbc-j^2bd}{c^2+d^2}$$

$$= \frac{ac+bd}{c^2+d^2} + \frac{j(bc-ad)}{c^2+d^2}$$

b) **Trigonometric form**

$$\begin{aligned} \frac{r_1 (\cos \phi_1 + j \sin \phi_1)}{r_2 (\cos \phi_2 + j \sin \phi_2)} &= \frac{(r_1 \cos \phi_1 + j \sin \phi_1)}{r_2 (\cos \phi_2 + j \sin \phi_2)} \times \frac{(\cos \phi_2 - j \sin \phi_2)}{(\cos \phi_2 - j \sin \phi_2)} \\ &= \frac{r_1 \cos (\phi_1 - \phi_2) + j \sin (\phi_1 - \phi_2)}{r_2 (\cos^2 \phi + \sin^2 \phi)} \\ &= \frac{r_1}{r_2} [\cos (\phi_1 - \phi_2) + j \sin (\phi_1 - \phi_2)] \end{aligned}$$

c) **Exponential form**

$$\frac{r_1 e^{j\phi_1}}{r_2 e^{j\phi_2}} = \frac{r_1}{r_2} e^{j(\phi_1 - \phi_2)}$$

d) **Polar Form**

$$\frac{r_1 \angle \phi_1}{r_2 \angle \phi_2} = \frac{r_1}{r_2} \angle \phi_1 - \phi_2$$

Note:-

1. Argument $(-\phi)$ indicates that angle is measured in clockwise direction from the reference axis.
2. The phasor $E \angle \phi$ in polar form can be converted into rectangular form $E = a + jb$.
Where $a = E \cos \phi$, $b = E \sin \phi$
3. ✓ Rectangular form is best suited for addition and subtraction of phasor quantities.
4. ✓ Polar form is best suited for multiplication and division of phasor quantities.

2.20.5 COMPLEX NOTATION OF A.C. CIRCUIT PARAMETERS

The voltage, current, impedance etc. may be represented by complex numbers.

For example, voltage may be represented as $V \angle \alpha = V(\cos \alpha + j \sin \alpha)$. The graphical representation of this voltage is a line segment of V units inclined at angle α to the reference axis. A current I lagging behind this voltage by an angle would be represented by $I \angle (\alpha - \phi) = I [\cos (\alpha - \phi) + j \sin (\alpha - \phi)]$.

In a purely resistive circuit, the impedance is represented by a real number. For inductive reactance the impedance is positive imaginary value and for capacitive reactance the impedance is negative imaginary value. Therefore impedance Z may be represented as

$$Z = R \pm jX = Z \angle \theta$$

✓ Where $Z = \sqrt{R^2 + X^2}$ and $\theta = \tan^{-1} X/R$

$$Z = R + jX_L \quad \text{or} \quad Z = R - jX_C$$

where $X_L = \omega L$ and $X_C = \frac{1}{\omega C}$

Example

Construct the phasor diagram and impedance triangle for the voltage and current given.

$$V = 150 \sin (5000t + 45^\circ)$$

$$I = 3 \sin (5000t - 15^\circ)$$

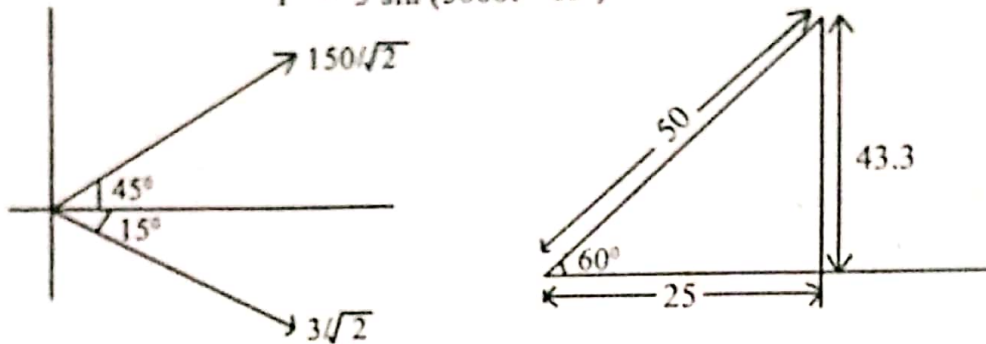

Fig 2.36.

Solution

$$V = \frac{150}{\sqrt{2}} \angle 45 \quad I = \frac{3}{\sqrt{2}} \angle -15$$

$$\begin{aligned} \text{Impedance } Z &= \frac{V}{I} = \frac{150/\sqrt{2} \angle 45}{3/\sqrt{2} \angle -15} \\ &= 50 \angle 60 \\ &= 50 (\cos 60 + j \sin 60) \\ &= 25 + j 43.3 \Omega \end{aligned}$$

2.21. AC THROUGH A PURELY RESISTIVE CIRCUIT

In a circuit containing pure ohmic resistor (ie, noninductive circuit) only, the potential difference (or ohmic drop) between any two points is given by:

$$V = iR \dots\dots\dots (i)$$

Where v = applied voltage to overcome the ohmic voltage drop only.

R = ohmic resistance and i = instantaneous current,

But for ac circuit $v = V_m \sin \theta = V_m \sin \omega t \dots\dots\dots (II)$

From equation (i) and (ii), we get

$$\begin{aligned} e &= iR = V_m \sin \omega t \dots\dots\dots (I) \\ i &= \frac{V_m \sin \omega t}{R} \end{aligned}$$

Now for $\sin \omega t = 1$, The value of current i is maximum

ie $I_m = V_m / R \dots\dots\dots (2)$

$\therefore i = I_m \sin \omega t \dots\dots\dots (3)$

From equations (1) and (3), it is clear that alternating voltage e and alternating current i are in phase with each other and hence, both of these can be represented by the sine wave [see fig. 2.30c]

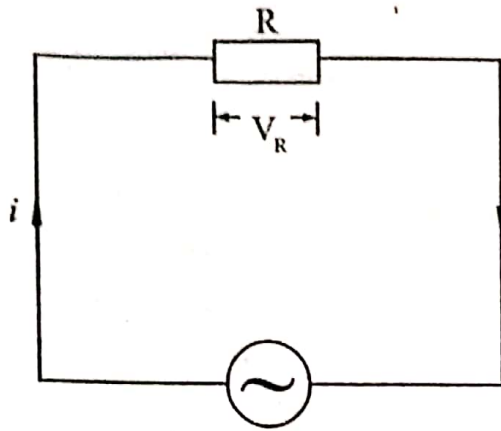

$V = V_m \sin \omega t$
Fig 2.30(a)

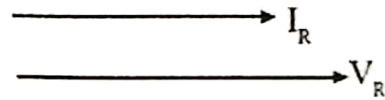

Phasor digram in R.M.S. value

Fig 2.30 (b)

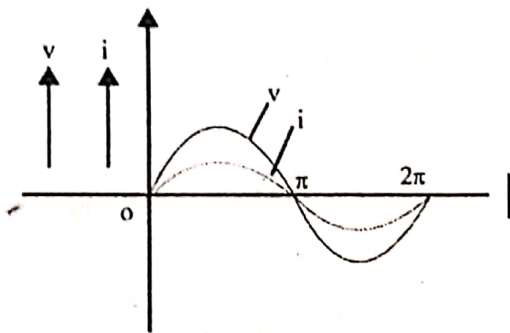

Fig 2.30 (c)

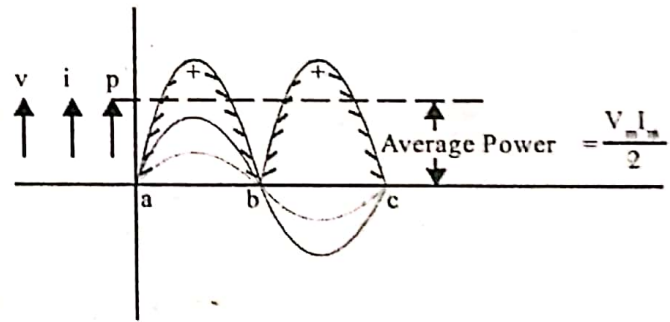

Fig 2.30 (d)

Dividing Equation (2.10) by $\sqrt{2}$ both side, we get

$$\frac{I_m}{\sqrt{2}} = \left(\frac{V_m}{\sqrt{2}} \right) / R$$

$$I_{rms} = V_{rms} / R$$

$$I_{rms} = V_{rms} / R \dots\dots\dots(4)$$

ie $V = IR$

2.21.1. Power in a purely resistive circuit

Instantaneous power (p) in any circuit is given by :

$$P = vi = V_m \sin \omega t \times I_m \sin \omega t = V_m I_m \sin^2 \omega t$$

$$= \frac{V_m I_m}{2} (1 - \cos 2\omega t)$$

$$= \frac{V_m I_m}{2} - \frac{V_m I_m}{2} \cos 2\omega t \dots \dots \dots (5)$$

Consequently power at any instant consists of two parts namely,

- i) The constant part $V_m I_m / 2$ and
- ii) The fluctuating part ie, $\frac{V_m I_m \cos 2\omega t}{2}$

Since power is a scalar quantity, we have to consider only average power. Now the average value of the double frequency component

$\frac{V_m I_m \cos 2\omega t}{2}$ is zero over a complete cycle.

∴ Power absorbed P = average of curve p.

$$= \frac{V_m I_m}{2} = \frac{V_m}{\sqrt{2}} \times \frac{I_m}{\sqrt{2}} = V_{rms} \times I_{rms} \text{ Watts} = VI \text{ watts.}$$

The power curve for a pure resistive circuit is also shown in fig 2.30d. Notice that power in pure resistive circuit is positive at all instants, ie. power in a purely resistive AC Circuit is never zero, this means that power is always absorbed in a resistive circuit and the same is dissipated as heat.

2.22. AC THROUGH PURELY INDUCTIVE CIRCUIT

Consider an ac circuit consisting of a pure inductance(L Henry) only as shown in fig. 2.21a. Let the applied alternating voltage be given by the equation,

$$v = V_m \sin \omega t \dots \dots \dots (1)$$

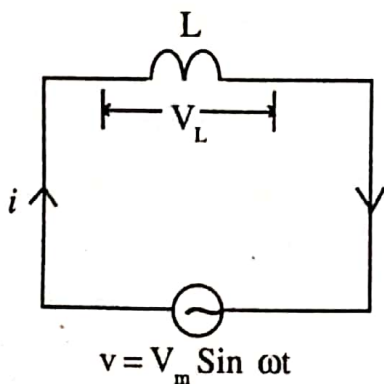

Fig 2.31 (a)

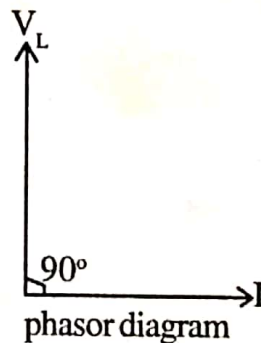

Fig 2.31 (b)

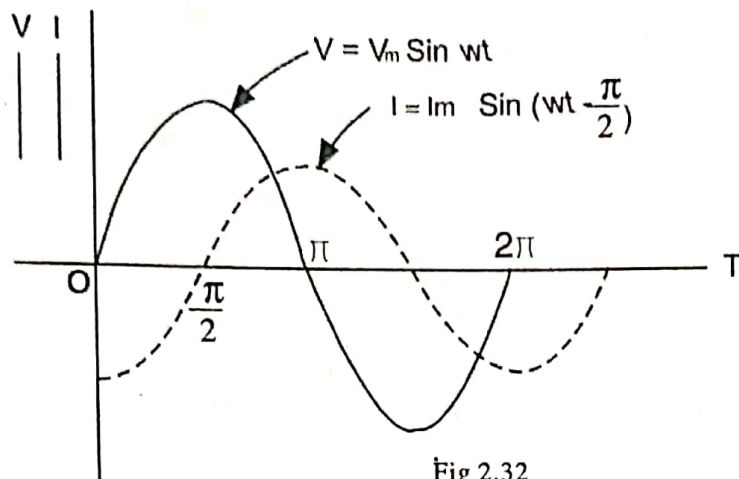

Fig 2.32

This alternating voltage will cause an alternating current i to flow through the circuit. Due to the inductance of the coil, a self-induced emf ($-Ldi/dt$ volt) is induced in the coil which opposes the applied voltage at every instant. As this circuit is purely inductive, there is no resistance and hence there is no ohmic drop. Thus the applied voltage has to overcome the self induced emf only at every instant.

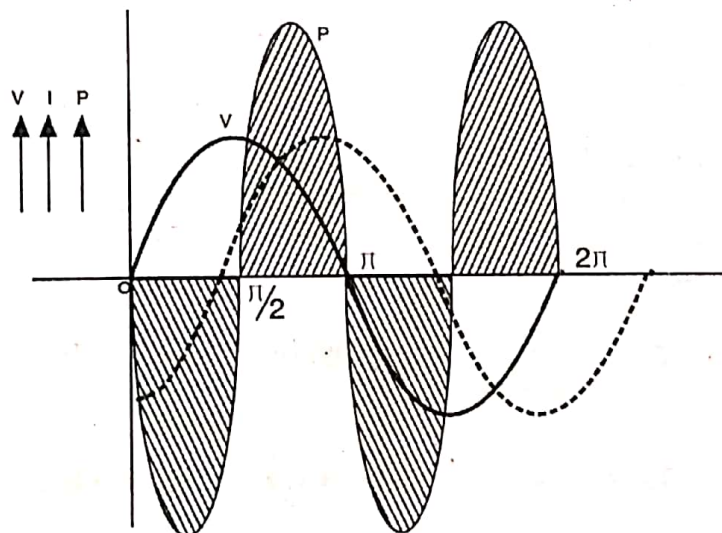

Fig 2.33

$$V_L = L \frac{di}{dt}$$

$$V_m \sin \omega t = L \frac{di}{dt}$$

$$\therefore di = \frac{V_m}{L} \sin \omega t dt$$

Integrating both sides we get

$$\begin{aligned} i &= \frac{V_m}{L} \int \sin \omega t dt = \frac{V_m}{\omega L} (-\cos \omega t) \\ &= \frac{V_m}{\omega L} \sin(\omega t - 90^\circ) \dots \dots \dots (2) \end{aligned}$$

For maximum value of current i ,

$$\sin \omega t - 90^\circ = 1 \quad \text{ie } I_m = \frac{V_m}{\omega L}$$

Hence equation (2) becomes

$$= I_m \sin(\omega t - 90^\circ) \dots\dots\dots(3)$$

Consequently equations (1) and (3) gives the voltage, and current flowing in purely inductive AC circuit. It is evident from these that current i in a purely inductive circuit lags the voltage v by 90° or $\pi/2$ radians. See fig 2.32.

The quantity ωL , which plays the part of resistance, of inductor is called inductive reactance X_L and is expressed in ohm, if L is in Henry and ω is in radian/ seconds (or Hertz). in other words inductive reactance is the opposition offered by the inductance to the alternating current flow.

2.22.1. Power in purely inductive AC circuit

Instantaneous value of power in pure inductive AC circuit is given by:

$$p = vi = V_m I_m \sin \omega t \sin(\omega t - \pi/2)$$

$$= -V_m I_m \sin \omega t \cos \omega t = \frac{-V_m I_m}{2} \sin 2\omega t$$

Power for complete cycle is given by :

$$P = \frac{-V_m I_m}{2} \int_0^{2\pi} \sin 2\omega t = \frac{-V_m I_m}{2} \left[\frac{-\cos 2\omega t}{2} \right]_0^{2\pi}$$

$$= \frac{V_m I_m}{2} \left[\frac{+1 - 1}{2} \right] = 0$$

Hence the average power demand (or dissipation) by a pure inductive AC circuit is zero. However the maximum value of instantaneous power (p) is $\frac{1}{2} V_m I_m$.

2.23. AC THROUGH PURELY CAPACITIVE CIRCUIT

Consider a capacitor of capacitance C Farads connected to an AC circuit (see fig 2.34a) of voltage

$$V_c = V_m \sin \omega t \dots\dots\dots(1)$$

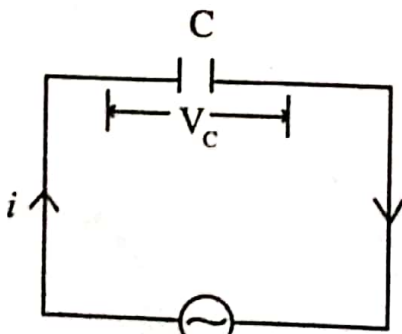

$v = V_m \sin \omega t$
Fig 2.34 (a)

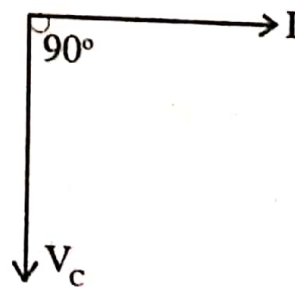

phasor diagram
Fig 2.34 (b)

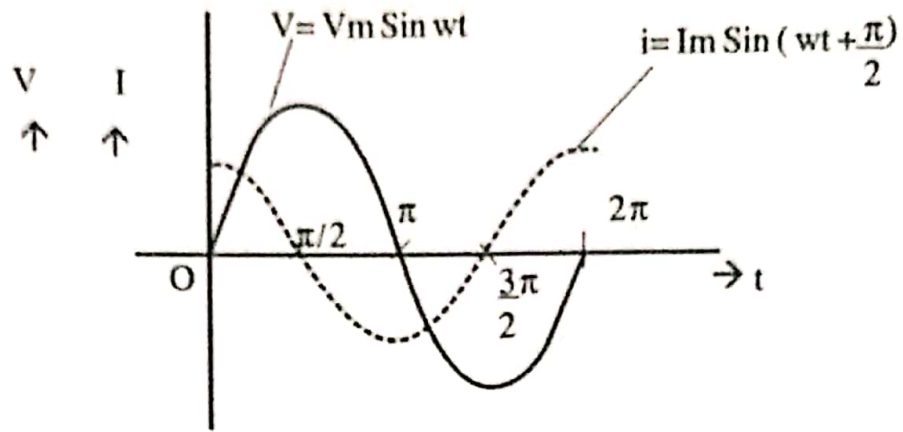

Fig 2.34(c)

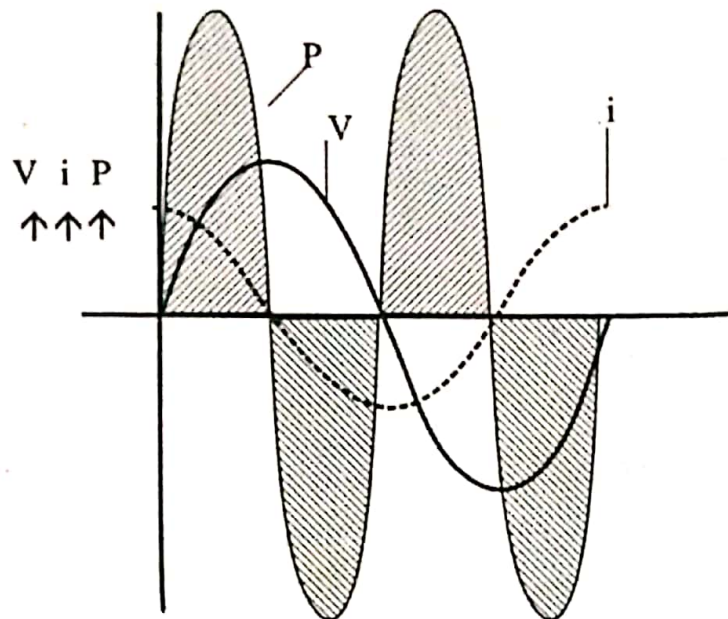

Fig 2.34(d)

Then the charge in the capacitor is given by

$$q = C.V_c = C.V_m \sin \omega t$$

Current i at any instant,

$$i = \text{Rate of flow of charge} = \frac{dq}{dt}$$

$$= \frac{d}{dt} (C.V_m \sin \omega t) = CV_m \cos \omega t \cdot \omega$$

$$i = \frac{V_m}{\left(\frac{1}{\omega C}\right)} \sin(\omega t + \pi/2) \dots \dots \dots (2)$$

The value of current i is maximum when

$$\sin(\omega t + \pi/2) = 1 \text{ ie,}$$

$$I_m = \frac{V_m}{\left(\frac{1}{\omega C}\right)}$$

Consequently, the factor $1/\omega C$ which acts as the resistance of the capacitor, is called capacitive reactance (X_c). Its unit is ohms if C is in farads and ω is in radians/sec.

From equations (1) and (2) we get,
 $i = I_m \sin(\omega t + \pi/2)$ (3)

Thus from equations (1) and (3), it is clear that the current i in a purely capacitive AC circuit leads the applied voltage by $\pi/2$ radians or 90° [See fig 2.34(b) and 2.34 (c)]

2.23.1 Power in a purely capacitive AC circuit

Instantaneous value of power in an AC circuit, containing capacitance only is given by

$$\begin{aligned} p &= v.i = V_m I_m \sin \omega t \sin(\omega t + \pi/2) \\ &= V_m I_m \sin \omega t \cos \omega t = \frac{V_m I_m \sin 2\omega t}{2} \end{aligned}$$

ie. the frequency of sine wave in the expression for power of a purely capacitive AC circuit is double that of emf as well as current waves.

Now total power for the whole cycle is given by:

$$P = \frac{V_m I_m}{2} \int_0^{2\pi} \sin 2\omega t = 0$$

Hence the average power demand (or dissipation) in a purely capacitive AC circuit is zero. (See Fig. 2.34d.)

However the maximum value of instantaneous Power (p) is $\frac{V_m I_m}{2}$

2.24. AC THROUGH SERIES R-L CIRCUIT

Consider a resistor of R ohms and an inductive coil of inductance L henries connected in series across an A.C. circuit see Fig 2.35a.

Let V = RMS value of applied voltage

I = RMS value of resultant current

V_R = IR = Voltage drop across R in phase with I

and V_L = IX_L = Voltage drop across L at right angles to I .

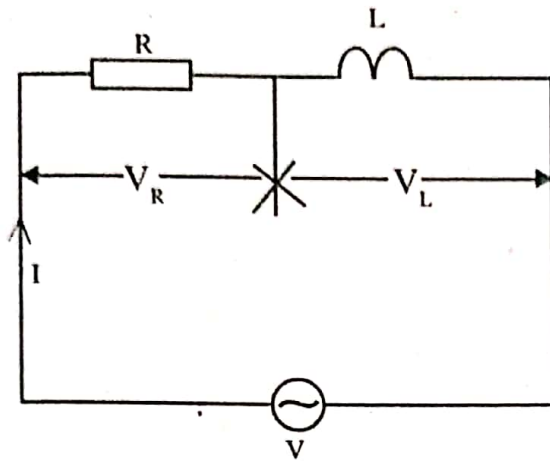

Fig 2.35 (a)

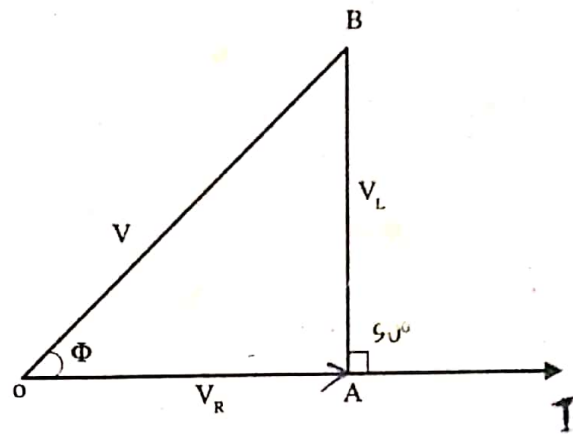

Fig 2.35 (b)

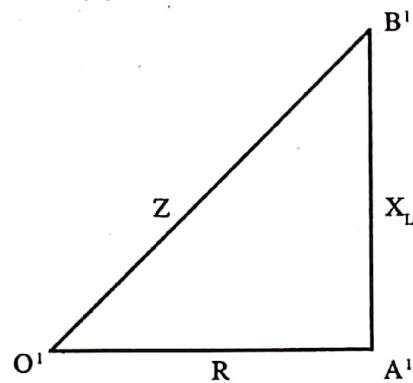

Fig 2.35 (c)

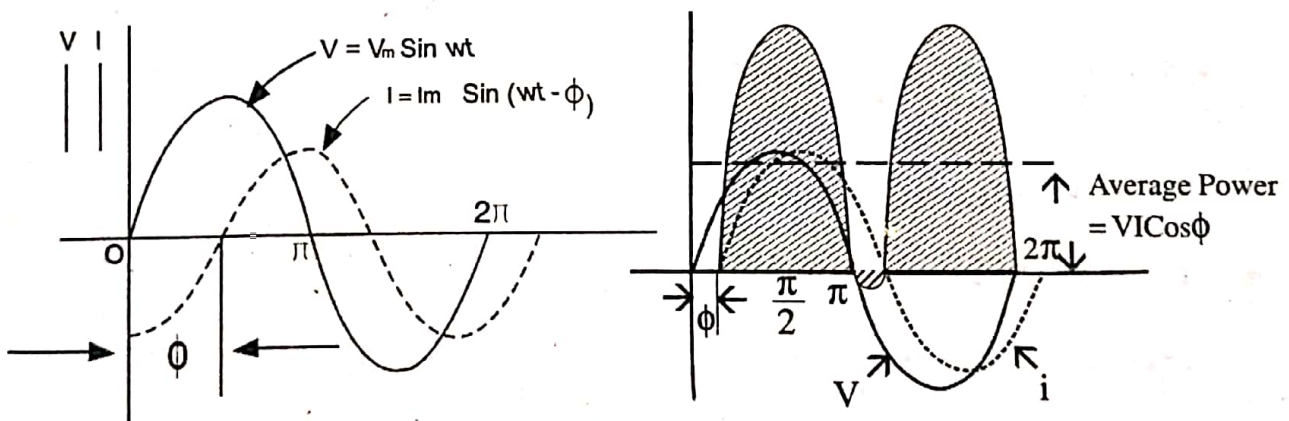

Fig 2.35 (d)

Phasor diagram (see fig. 2.35 b) shows that phasors OA and AB represent the ohmic drop (V_R) and the inductive drop (V_L) respectively. Consequently, the applied voltage (V) is the phasor sum of these two.

$$\text{ie } V = \sqrt{V_R^2 + V_L^2} = \sqrt{(IR)^2 + (IX_L)^2} = I \sqrt{R^2 + X_L^2}$$

$$I = \frac{V}{\sqrt{R^2 + X_L^2}} = \frac{V}{Z}$$

The quantity $\sqrt{R^2 + X_L^2}$ possessing the unit of ohms, is called impedance (Z) of circuit.

$$V = IZ, V_R = IR \text{ and } V_L = IX_L$$

The triangle OAB (see fig 2.35b) is called the voltage triangle, while the triangle O'A'B' (see fig 2.35c) whose sides represent R, XL and Z is called the impedance triangle. It can easily be noticed that the phasor V leads the phasor I by an angle ϕ or current I lags the voltage V by an angle ϕ see fig. 2.35.d)

Such that

$$\tan\phi = \frac{X_L}{R} = \frac{\omega L}{R} = \frac{\text{Reactance}}{\text{Resistance}}$$

$$\phi = \tan^{-1} \frac{X_L}{R}$$

Power in series R-L Circuit

Let us resolve current I into two mutually perpendicular components (See fig 2.36), $I \cos\phi$ along the applied voltage V and $I \sin\phi$ perpendicular (or in quadrature) to applied voltage (V).

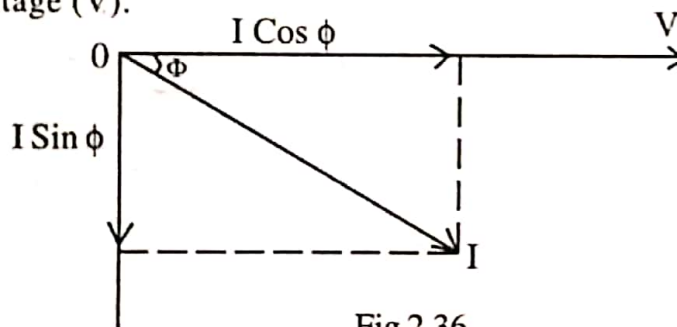

Fig 2.36

$$\begin{aligned} \text{Instantaneous power } p &= vi \text{ watts} \\ &= V_m \sin\omega t \times I_m \sin(\omega t - \phi) \\ &= \frac{V_m I_m [\cos\phi - \cos(2\omega t - \phi)]}{2} \end{aligned}$$

Thus we see that the instantaneous power consists of two parts

a) A constant part $\left(\frac{V_m I_m \cos\phi}{2}\right)$ and

b) A double frequency component $1/2 V_m I_m \cos(2\omega t - \phi)$ whose average value over a complete cycle is zero

$$\begin{aligned} \text{Average power } P &= 1/2 V_m I_m \cos\phi = \frac{V_m}{\sqrt{2}} \frac{I_m}{\sqrt{2}} \cos\phi \\ &= VI \cos\phi \end{aligned}$$

The term $\cos\phi$ (ie cosine of angle by which the current phasor lags the voltage phasor) is called power factor (pf) of the circuit. thus power factor is the cosine of lag angle or the ratio of resistance to impedance or $\cos\phi = R/Z$.

2.25. APPARENT POWER, ACTIVE POWER AND REACTIVE POWER

1. Apparent Power (S) :

In an a.c. circuit the product of rms values of applied voltage and current is called apparent power.

$$\text{Apparent power} = V_{\text{rms}} I_{\text{rms}}$$

Apparent power is measured in volt ampere (VA) or in Kilovolt ampere (kVA).

2. Active Power (P)

The power actually consumed in an a.c. circuit is called active power or real power. It is measured in watts. If V and I are the rms values of voltage and current respectively and $\cos\phi$ the power factor of the circuit, then,

$$\text{Active power } P = VI \cos\phi \text{ watt.....(1)}$$

$$= \text{Apparent power} \times \text{power factor}$$

$$= \text{KVA} \times \cos\phi \text{ watts.}$$

The unit of active power is watts or kilo watts (kW)

$I \cos\phi$ is the component of I in phase with applied voltage V (see Fig 2.36), $I \cos\phi$ is known as active or wattfull or power component of current.

Put $\cos\phi = R/Z$ in equation(1)

$$\text{We get } P = \frac{VI.R}{Z} = \frac{IZ.IR}{Z} = I^2R \text{ watts.}$$

[That is the active power in an ac circuit is power consumed in the resistance only.]

3. Reactive Power (Q)

The Component of I in quadrature with the applied voltage V (ie $I \sin\phi$) is known as reactive or wattless component of current. The product of rms value of voltage (V) and reactive component of current ($I \sin\phi$) is called the reactive power.

$$\text{ie, } Q = VI \sin\phi \text{ watts.}$$

$$= \text{apparent power} \times \sin\phi.$$

The unit of reactive power is VAR (Volt ampere reactive) or kVAR.

2.26 IMPEDANCE TRIANGLE AND POWER TRIANGLE

The circuit parameters resistance, reactance and impedance can be represented by the sides of a right angled triangle as shown in fig. 2.37a., This triangle is known as impedance triangle of the circuit.

From the impedance triangle, the phase angle ϕ (between applied voltage and circuit current) is obtained as

$$\phi = \cos^{-1} \frac{R}{Z}$$

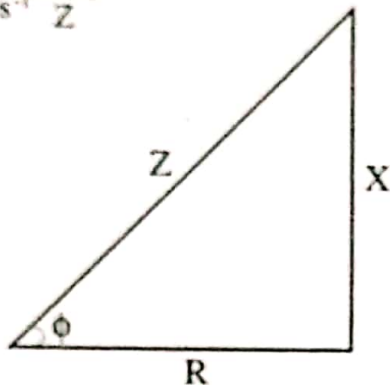

Fig 2.37(a)

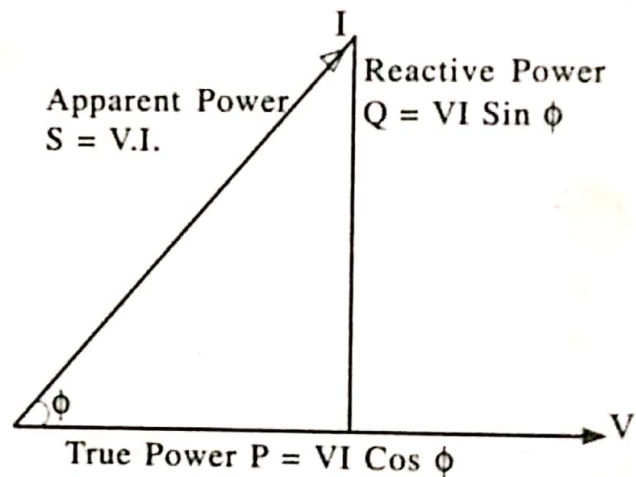

Fig 2.37(b)

The three powers (apparent power, active power and reactive power) can also be represented by a right angled triangle called power triangle.

From power triangle,

- 1) $pf = \frac{\text{Active Power}}{\text{Apparent Power}}$
- 2) $kVA = \sqrt{kW^2 + kVAR^2}$

2.27. A C THROUGH SERIES R.C CIRCUIT

Consider an AC circuit in which a resistor of R ohms and a capacitor of capacitance C farad are connected in series. (See fig. 2.38a)

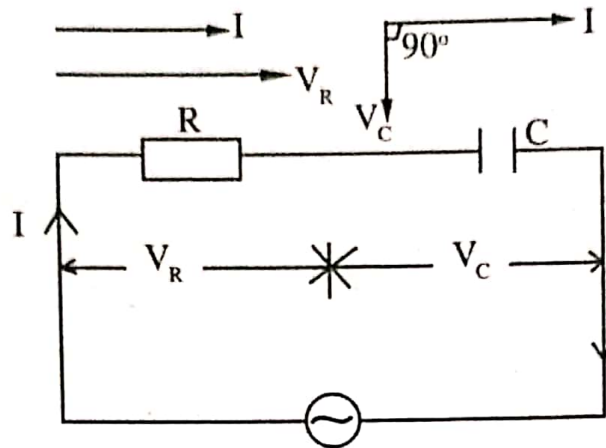

Fig. 2.38 (a)

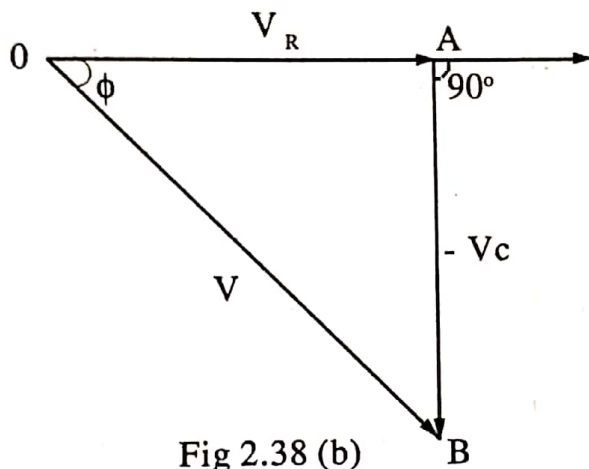
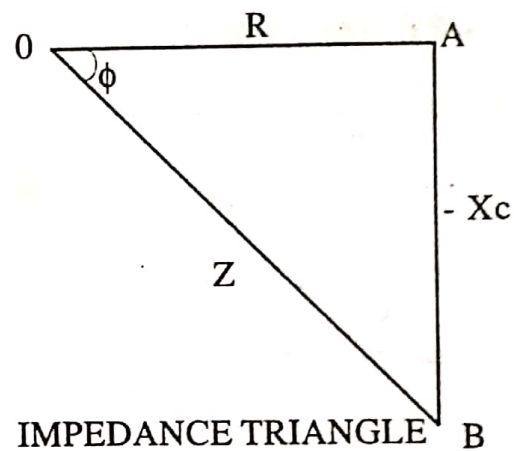

Fig 2.38 (b)



IMPEDANCE TRIANGLE

Fig 2.38 (c)

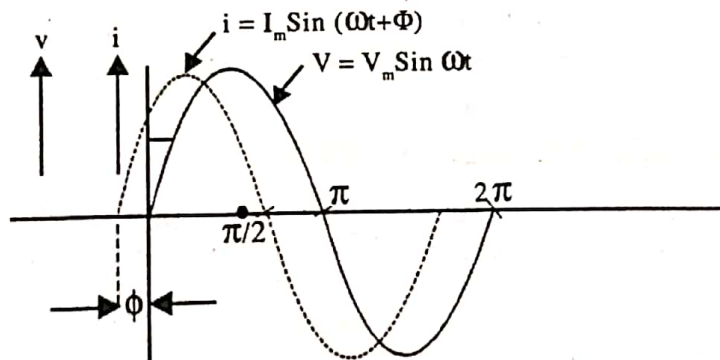

Fig 2.38(d)

- Let V = RMS value of applied voltage
 I = RMS value of resultant current
 V_R = IR = Voltage drop across R in phase with I
 And V_C = IX_C = Voltage drop across C lagging I by $\pi/2$ radians.

Since the capacitive reactance X_C is regarded as negative, V_C is shown along the negative direction of Y -axis (ie. downwards) in the voltage triangle OAB (See Fig.2.38b)

$$V^2 = V_R^2 + V_C^2 = (IR)^2 + (-IX_C)^2 = I^2 (R^2 + X_C^2)$$

$$I = \frac{V}{\sqrt{R^2 + X_C^2}} = \frac{V}{Z}$$

Where Z is called the impedance of the circuit. Fig 2.38c shows the impedance triangle OAB in which sides represent R, $-X_C$ and Z. It can easily be noted that current I leads the voltage V by an angle ϕ (See fig 2.38d).

$$\text{Such that } \tan \phi = \frac{X_C}{R}$$

\therefore Corresponding instantaneous values of

$$\text{Voltage, } v = V_m \sin \omega t$$

$$\text{and current } i = I_m \sin(\omega t + \phi)$$

Power In RC series Circuit

$$\text{Instantaneous power } p = vi \text{ watts}$$

$$= (V_m \sin \omega t) I_m \sin(\omega t + \phi)$$

$$= 1/2 V_m I_m (\cos \phi - \cos (2\omega t + \phi))$$

$$\text{Average power } P = 1/2 V_m I_m \cos \phi$$

$$= VI \cos \phi.$$

$$= (IZ) I \left(\frac{R}{Z} \right) = I^2 R \text{ watts}$$

2.28. A C THROUGH SERIES RLC CIRCUIT

Consider an AC Circuit containing a resistor of resistance R ohm, an inductor of inductance L henries and a capacitor of capacitance C farads, all connected in series across AC supply of RMS voltage V volts and RMS current I amperes see fig 2.39 (a).

Let $V_R = IR =$ Voltage drop across R in phase with current I

$V_L = IX_L = I\omega L =$ Voltage drop across L, leading I by $\pi/2$ radans.

$V_C = IX_C = I \frac{1}{\omega C} =$ Voltage drop across C lagging I by $\pi/2$ radians

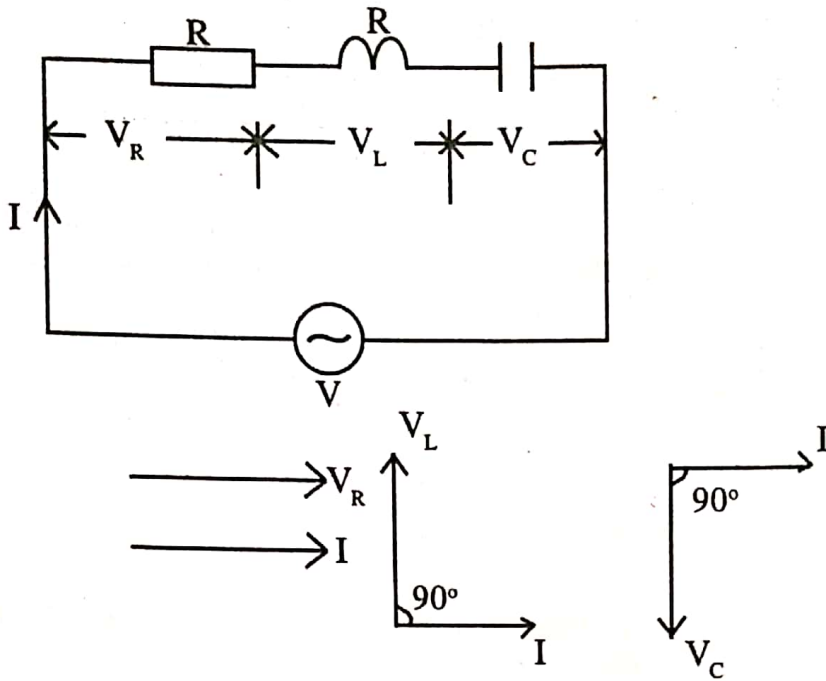

Fig. 2.39 (a)

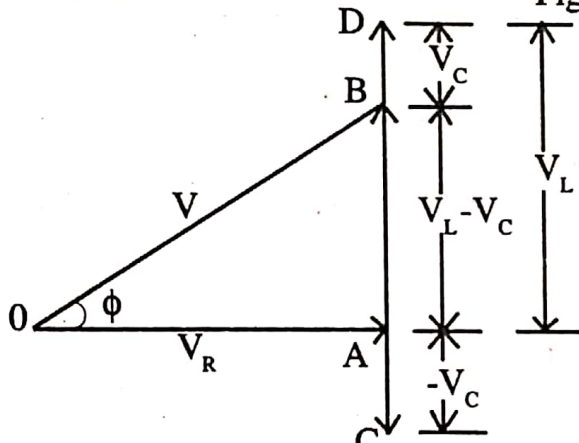

Fig 2.39 (b)

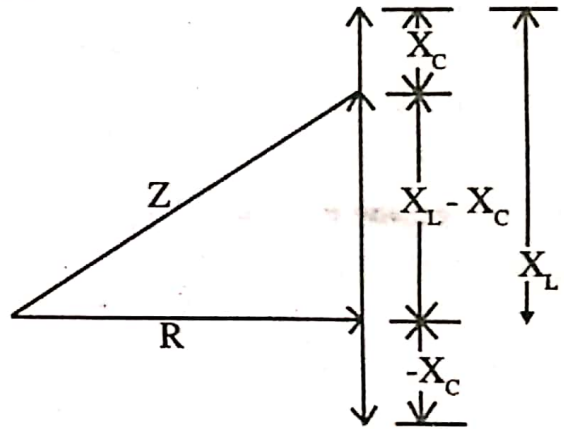

Fig 2.39 (c)

In the voltage triangle OAB (See fig 2.39 b)OB, OA and AB represent V, V_R and $(V_L - V_C)$ respectively. It may be noted that V_L and V_C are out of phase by π radians or 180° with each other ie. they are directly in opposition to each other. in the diagram V_L has been assumed to be greater in magnitude than V_C . Hence the net reactive drop = AB.

$$V_L - V_C = I(X_L - X_C)$$

But the applied voltage (V.) represented by OB is vector sum of OA and AB

ie,
$$V = \sqrt{V_R^2 + (V_L - V_C)^2} = \sqrt{(IR)^2 + (IX_L - IX_C)^2}$$

$$= I \sqrt{R^2 + (X_L - X_C)^2}$$

$$I = \frac{V}{\sqrt{R^2 + (X_L - X_C)^2}} = \frac{V}{\sqrt{R^2 + X^2}} = \frac{V}{Z}$$

where Z = impedance of the circuit and
 X = net reactance ($X_L - X_C$)
 $\therefore Z^2 = R^2 + X^2$

The phase angle ϕ is given by

$$\tan\phi = \frac{X_L - X_C}{R} = \frac{X}{R} = \frac{\text{Net Reactance}}{\text{Resistance}}$$

\therefore Voltage and the resulting current are given by

$$v = V_m \sin\omega t \dots\dots\dots(1)$$

$$i = I_m \sin(\omega t \pm \phi) \dots\dots\dots(2)$$

When current leads (ie $X_C > X_L$), then positive (+) sign is to be used in (2) but when current lags (ie $X_L > X_C$), then negative sign (-) is to be used in (2)

$$\text{Power factor} = \cos\phi = \frac{R}{Z} = \frac{R}{\sqrt{R^2 + (X_L - X_C)^2}}$$

$$\begin{aligned} \text{Power consumed, } P &= \text{Voltage} \times \text{component of current in} \\ &\text{phase with voltage} \\ &= VI \cos\phi \end{aligned}$$

2.29. EXAMPLES

1 A resistance of 50Ω is connected across a supply voltage $v = 50 \sin 314 t$. Calculate the power dissipated in the resistor.

Solution

$$v = 50 \sin 314 t.$$

$$V_m = 50$$

$$R = 50$$

$$I_m = V_m / R = 50 / 50 = 1 \text{ A}$$

$$\text{Power dissipated} = VI \text{ watts}$$

$$= \frac{V_m}{\sqrt{2}} \frac{I_m}{\sqrt{2}} \text{ watts} = (50 \times 1) / 2 = 25 \text{ watts.}$$

2 A 50Hz alternating voltage of 220V produces a current of 2.2 ampere in a pure inductance coil. Determine:

- Inductive reactance of the coil.
- Inductance of the coil and
- Power absorbed.

Also write the equation for applied voltage and current.

Solution

rms value of applied voltage

$$V = 220 \text{ Volt}$$

rms value of current $I = 2.2\text{A}$

frequency $f = 50 \text{ Hz}$

a) Inductive reactance of the coil,

$$X_L = \frac{V}{I} = \frac{220}{2.2} = 100\text{ohm}$$

b) Inductance of the coil

$$L = \frac{X_L}{\omega} = \frac{X_L}{2\pi f} = \frac{100}{2\pi \times 50} = 0.318 \text{ H}$$

c) Power absorbed $P = 0$

Peak value of current voltage $V_m = \sqrt{2} \times 220 = 311.13 \text{ volt.}$

Equation for applied voltage is

$$v = V_m \sin(2f\pi t) = 311.13 \sin(2\pi \times 50 \times t)$$

$$v = 311.13 \sin(314t)\text{volt.}$$

Peak value of current $I_m = \sqrt{2} \times 2.2 = 3.11\text{A}$

equation for current is

$$i = I_m \sin(\omega t - \pi/2)$$

$$i = 3.11 \sin(2\pi f t - \pi/2)$$

$$i = 3.11 \sin(2\pi \times 50t - \pi/2)$$

$$i = 3.11 \sin(314t - \pi/2) \text{ amp.}$$

3 A capacitance of $40\mu\text{F}$ is supplied with a potential difference of 220 volt(rms). What must be the frequency, if the current is to be (a) 2.765 amp and (b) 5.53 amp.

Solution

rms value of potential difference $V = 220\text{V}$

rms value of current $I = V/X_c = \frac{V}{1/\omega c}$

$$I = \omega.C.V = 2\pi f CV$$

$$f = \frac{I}{2\pi VC} = \frac{I}{2\pi \times 220 \times 40 \times 10^{-6}} = \frac{I}{0.0553}$$

a) When $I = 2.765\text{amp}$

$$f = \frac{2.765}{0.0553} = 50\text{Hz.}$$

b) When $I = 5.53 \text{ amp}$

$$f = \frac{5.53}{0.0553} = 100\text{Hz.}$$

10

A series circuit consists of a 300Ω non-inductive resistor, a $7.95\ \mu\text{F}$ capacitor and a $2.06\ \text{H}$ inductor of negligible resistance. If the supply voltage is 250V at 50Hz . calculate (a) the circuit current (b) the phase angle (c) the voltage drop across each element.

Solution

$$R = 300\Omega, \quad L = 2.06\ \text{H}$$

$$C = 7.95\ \mu\text{F} = 7.95 \times 10^{-6}\ \text{F}$$

$$V = 250\ \text{V}, \quad f = 50\text{Hz}.$$

Inductive reactance of the circuit

$$X_L = 2\pi fL = 2\pi \times 50 \times 2.06 = 647\Omega.$$

Capacitive reactance of the circuit

$$X_C = \frac{1}{2\pi fC} = \frac{1}{2\pi \times 50 \times 7.95 \times 10^{-6}} = 400\Omega$$

Net reactance of the circuit

$$X = X_L - X_C \\ = 647 - 400 = 247\Omega$$

Since $X_L > X_C$ the circuit is predominantly inductive.

Impedance of the circuit

$$Z = \sqrt{R^2 + (X_L - X_C)^2} = \sqrt{300^2 + 247^2} = 388.6\Omega$$

$$\text{a) Current in the circuit } I = V/Z = 250/388.6 = 0.643\ \text{A}$$

$$\text{b) } \cos\phi = R/Z = 300/388.6 = 0.772$$

$$\text{Phase angle } \phi = \cos^{-1}(0.772) = 36.46^\circ (\text{lag})$$

c) Voltage drop across the resistor

$$V_R = IR = 0.643 \times 300 = 193.9\ \text{V}$$

Voltage drop across the inductor

$$V_L = IX_L = 0.643 \times 647 = 416\ \text{V}$$

Voltage drop across the capacitor

$$V_C = I.X_C = 0.643 \times 400 = 257.2\ \text{V}$$

Q) When an alternating voltage of $(80 + j60)V$ is applied to a circuit, the resulting current flow is $-4 + j10A$. Find the impedance, power consumed, and phase angle of the circuit.

soln

$$V = 80 + j60 = 100 \angle 36.86$$

$$I = -4 + j10 = 10.77 \angle 111.8$$

$$Z = \frac{V}{I} = \frac{100 \angle 36.86}{10.77 \angle 111.8} = 9.28 \angle \overset{\phi}{-74.94} \Omega$$

$$\text{Power} = V I \cos \phi = 100 \times 10.77 \cos(74.94) \\ = \underline{\underline{280.1 \text{ W}}}$$

$$\text{phase angle, } \phi = \underline{\underline{74.94^\circ}}$$

1. Two impedances Z_1 and Z_2 when connected separately across 220V, 50Hz supply, consume 300W and 150W at a power factor of 0.4 lagging and 0.7 leading respectively. When the two impedances are connected in series across the same supply, find the total power consumed and overall power factor

$$V = 220V$$

$$P_1 = 300W, \quad \cos \phi_1 = 0.4 \text{ lag}$$

$$P_2 = 150W, \quad \cos \phi_2 = 0.7 \text{ lead}$$

$$P = V I \cos \phi$$

when Z_1 is connected

$$I_1 = \frac{300}{220 \times 0.4} = 3.4A$$

$$Z_1 = \frac{V}{I_1} = \frac{220}{3.4} = 64.7 \Omega$$

$$\cos \phi_1 = 0.4 \text{ lag}$$

$$\phi_1 = 66.42^\circ$$

$$Z_1 = 64.7 \angle 66.42^\circ$$

$$= 25.88 + j59.29$$

When Z_2 is connected,

$$I_2 = \frac{150}{220 \times 0.7} = 0.974A$$

$$Z_2 = \frac{V}{I_2} = \frac{220}{0.974} = 225.87 \Omega$$

$$\cos \phi_2 = 0.7 \text{ lead}$$

$$\phi_2 = 45.57^\circ$$

$$Z_1 = 225.87 \angle -45.57$$

$$Z_2 = 158.12 - j161.3$$

Z_1 & Z_2 in series

$$Z = Z_1 + Z_2$$

$$= 25.88 + j59.29 + 158.12 - j161.3$$

$$= 184 - j102.01 = 210.385 \angle -29$$

$$I = \frac{V}{Z} = \frac{220}{210.385 \angle -29} = 1.045 \angle 29$$

$$\cos \phi = \cos 29 = 0.8746 \text{ lead.}$$

② Coil A having resistance of 20Ω and inductance of 0.2 H is connected in series with another coil B having resistance of 15Ω and inductance of 0.1 H .

The two coils in series are fed from 220 V , 50 Hz single phase power supply. Determine.

- (i) Voltage across each coil
- (2) power dissipated in each coil
- (3) p.f. of the whole circuit.

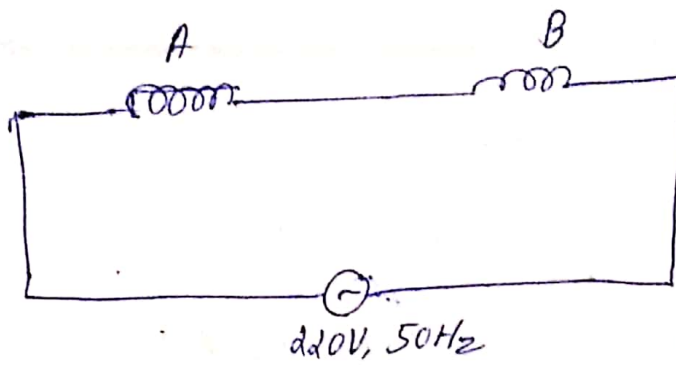

$$V = 220V$$

$$R_1 = 20\Omega$$

$$L_1 = 0.2H$$

$$X_1 = \omega L = 2\pi \times 50 \times 0.2 = 62.83\Omega$$

$$Z_1 = 20 + j62.83 = 65.93 \angle 72.34^\circ$$

$$R_2 = 15\Omega$$

$$L_2 = 0.1H$$

$$X_2 = \omega L = 2\pi \times 50 \times 0.1 = 31.41\Omega$$

$$Z_2 = R_2 + jX_2 = 15 + j31.41\Omega$$

$$= 34.8 \angle 64.47^\circ$$

Total impedance, $Z = Z_1 + Z_2$

$$= 20 + j62.83 + 15 + j31.41$$

$$= 35 + j94.24$$

$$= 100.52 \angle 69.62^\circ$$

$$I = \frac{V}{Z} = \frac{220}{100.52 \angle 69.62^\circ} = 2.188A \angle -69.62^\circ$$

$$V_1 = IZ_1 = 2.188 \angle -69.62^\circ \times 65.93 \angle 72.34^\circ$$

$$= 144.267 \angle 2.82^\circ$$

$$V_2 = IZ_2 = 2.188 \angle -69.62^\circ \times 34.8 \angle 64.47^\circ$$

$$= 76.142 \angle -5.05^\circ$$

$$P_A = I^2 R_A = (2.188)^2 \times 20 \\ = \underline{\underline{95.74 \text{ W}}}$$

$$P_B = I^2 R_B = (2.188)^2 \times 15 \\ = 71.81 \text{ W}$$

Max angle of wkt ckt, $\phi = 69.62$

$$\text{power factor, } = \cos 69.62 \\ = \underline{\underline{0.349}}$$

4.1 THREE PHASE SYSTEM

INTRODUCTION

The a.c. circuits discussed so far are termed as single phase circuits because they contain a single alternating current and voltage wave. A single phase generator producing a single phase supply has only one armature winding. A two phase generator producing two phase voltage has two windings displaced by 90° and a three phase generator has three winding displaced by 120° . In general we can say that a poly phase system has many phases or circuits, each phase having a single alternating voltage of equal magnitude and frequency but displaced from one another by equal electrical angles. Although several polyphase systems are possible the three phase system is the most popular one.

4.1.1 Reasons for the use of Three Phase System

Electric power is generated, transmitted and distributed in the form of 3 phase power. Homes and small establishments have single phase power but this merely represents a tap-off from the basic three phase system.

Advantages of three phase power over single phase power are $3\phi \leftrightarrow 1\phi$.

1. For a given size of frame, a three phase generator or motor has greater output than that of a single phase genertor.
2. Three phase generators work in parallel without any difficulty.
3. Three phase transmission line requires lesser amount of conductor material for transmitting the same amount of power over a single phase line.
4. Three phase motors possess uniform torque whereas single phase motors possess a pulsating torque.
5. Poly phase induction motors are self starting whereas single phase a.c. motors are not self starting.

4.1.2 Elementary three phase alternator

Figure shows an elementary three phase alternator. The three identical coils A, B, and C are symmetrically placed in such a way that emf s induced in them are displaced by 120° (elect) from one another. Since the coils are identical and are subjected to the same rotating field the emf s induced in them will be of same magnitude and frequency.

The equations of the three emf s are

$$e_A = E_m \sin \omega t$$

$$e_B = E_m \sin (\omega t - 120^\circ)$$

$$e_C = E_m \sin (\omega t - 240^\circ)$$

Figure shows the wave diagram of the three emf s and also the phasor diagram.

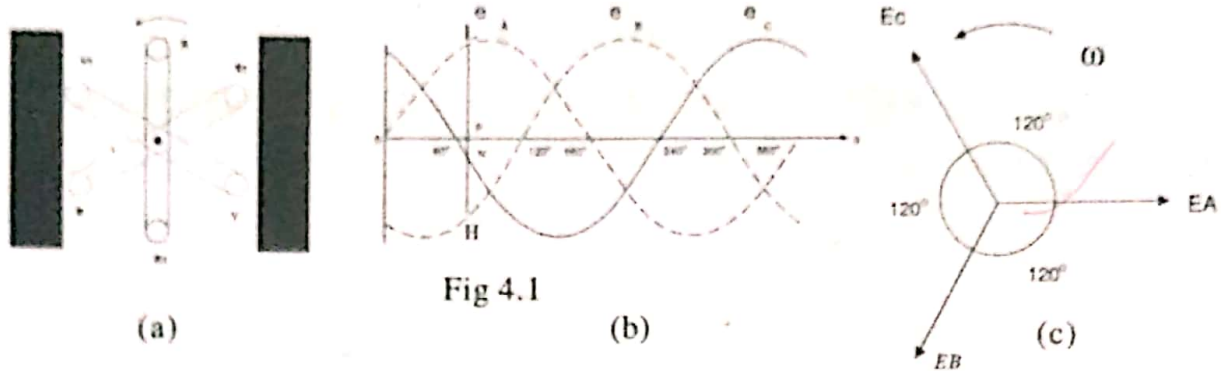

Fig 4.1

It can be proved that the sum of the three emfs at any instant is zero.

$$\begin{aligned}
 1. \quad e &= e_A + e_B + e_C \\
 &= E_m [\sin \omega t + \sin (\omega t - 120^\circ) + \sin (\omega t - 240^\circ)] \\
 &= E_m [\sin \omega t + 2 \sin (\omega t - 180^\circ) \cos 60^\circ] \\
 &= E_m [\sin \omega t - 2 \sin \omega t \cos 60^\circ] = 0
 \end{aligned}$$

2. Referring to the wave diagram the sum of the three emfs at any instant is zero. For example at the instant P, ordinate PL is positive while the ordinates PN and PH are negative. If actual measurements are made it will be seen that

$$PL + (-PN) + (-PH) = 0$$

3. Since the three windings or coils are identical, $E_A = E_B = E_C = E$ in magnitude. As shown in figure 4.2 resultant of E_A and E_B is E_r and to its magnitude is $2E \cos 60^\circ = E$. This resultant is equal and opposite to E_C . Hence the resultant of the three emfs is zero.

4. Using complex algebra we can again prove that the sum of the three emf s is zero. Thus taking E_A as reference phasor we have

$$E_A = E \angle 0^\circ = E + j0$$

$$E_B = E \angle -120^\circ = E(-0.5 - j0.866)$$

$$E_C = E \angle -240^\circ = E(-0.5 + j0.866)$$

$$E_A + E_B + E_C = (E + j0) + E(-0.5 - j0.866) + E(-0.5 + j0.866) = 0$$

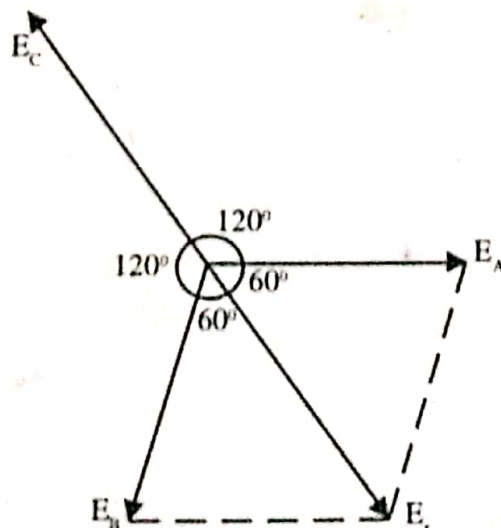

Fig. 4.2

4.1.3 Phase sequence:

The order in which the voltages in the three phases or coils reach their maximum or any instantaneous value is called the phase sequence or the phase order. Thus in figure the three coils A, B and C are producing voltages that are displaced by 120° (electrical) from one another. (Referring to the phasor dia (fig. 4.3) it is easy to see that voltage in coil A attains maximum positive value first, next coil B and then coil C. Hence the phase sequence is ABC. If the direction of rotation of the alternator is reversed, then the order in which the three phases attain their max positive value would be ACB. Hence the phase sequence is ACB.) The three phases may be numbered (1,2,3) or lettered (A,B,C) or the three phases may be named after the three natural colours that is Red R, Yellow Y and blue B. In this case phase sequence is RYB or RBV.

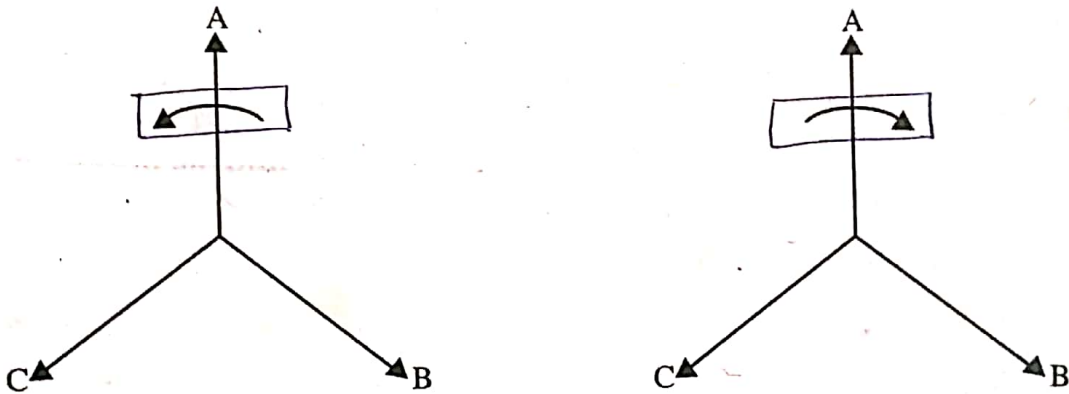

Fig. 4.3

PHASOR VOLTAGES

The selection of a phase angle for one voltage in a three-phase system fixes the angles of all other voltages. In this chapter, an angle of zero will always be associated with the phasor voltage of line B with respect to line C: $V_{BC} = V_L \angle 0^\circ$. It is shown that the line to -line voltage V_L is $\sqrt{3}$ times the line to neutral voltage. All ABC sequence voltages in Fig. 4.4.

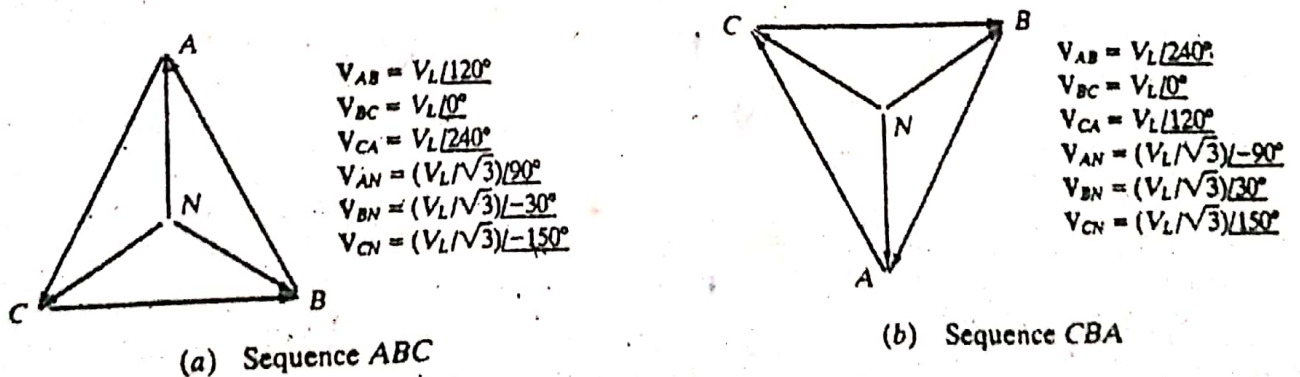

Fig. 4.4

4.1.4 Double subscript notation: The double subscript notation is a very useful concept and may be found advantageous in the analysis of three phase systems. In this notation two letters are placed at the foot of the symbol for voltage or current. The two letters indicate the two points between which voltage or current exists and the order of the letters indicates the relative polarity of voltage or current during positive half cycle.

eg: → Thus (V_{RY}) indicates a voltage V between points R and Y with point R being positive w.r.t. Y during its positive half cycle.

ie. $V_{RY} = -V_{YR}$

eg: Again (I_{RY}) indicates a current I between points R and Y and that its direction is from R to Y during its positive half cycle.

Advantage of using double subscript notation is that the subscripts and the order of the subscripts describe the quantity completely.

4.1.5 Symmetrical and balanced three phase systems

(A system is said to be symmetrical when the various voltages are equal in magnitude and are displaced from one another by equal angles) (The system is balanced when the various voltages are equal in magnitude, the various currents are equal in magnitude and the phase angle are the same for each phase.)

4.1.6 Methods of connection of three phase system

Since a voltage is generated in each coil, it may be considered as a source of voltage. The three coils together constitute a three phase system and each coils is a phase. Let a load be connected across each phase. The arrangement given in figure 3.27 shows three loads supplied separately from three phases of a generator. The end of a coil where the current leaves may be called the starting end or simply the start.

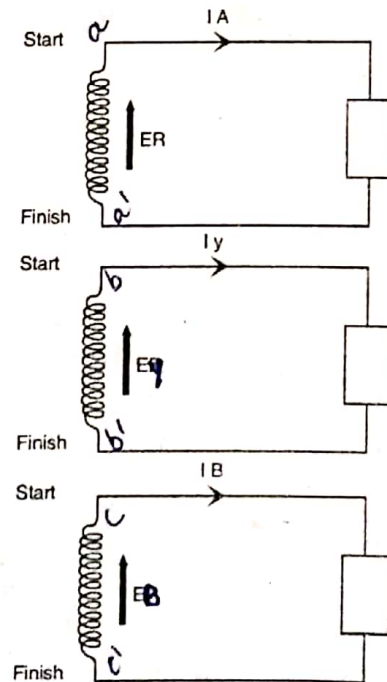

Fig. 4.5

The other end where the current enters the coil is called the finishing end or simply the finish. The ends a,b,c are the starting ends while a',b',c' are the finishing ends. The arrangement thus shown requires six wires to connect the loads. This is equivalent to three separate single phase systems. Such a system is called a three phase, six wire system. The number of connecting wires may be reduced by the interconnection of the phases to form a single three phase a.c. system. There are two methods of interconnecting the three phases. These are called (1) Star (Y) and (2) Delta (Δ) connections.

1. In Y connection, similar ends (start or finish) of the three phases are joined together within the alternator and the three lines are run from the other free ends as shown in figure (Fig. 4.6a). The common point N may or may not be brought out. If a neutral conductor is present it is called a three phase four wire system.

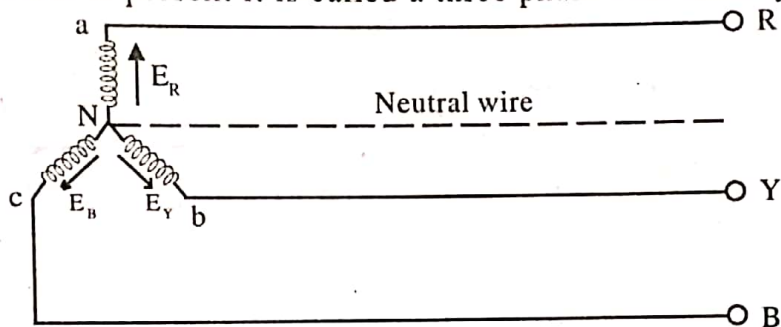

Fig. 4.6(a)

2. In Δ connection, dissimilar ends (start or finish) of the phases are joined to form a closed mesh and the three lines are run from the junction points as shown in figure (Fig. 4.6b). In Δ connection no neutral point exists and hence only a three phase three wire system can be formed.

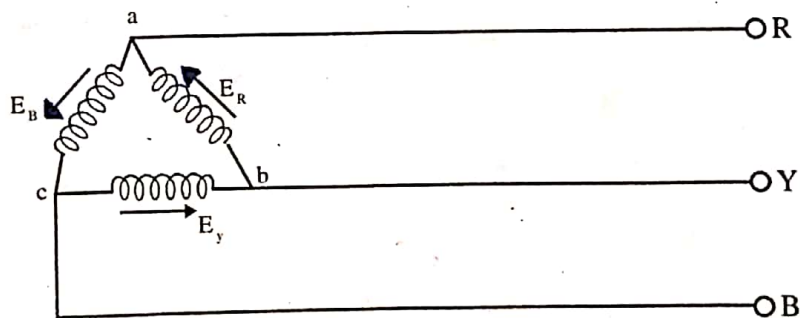

Fig. 4.6 (b)

4.2 STAR OR WYE CONNECTION

In this method, similar ends of the three phases are joined together to form a common junction N called (star) or (neutral point). The three line conductors are run from the three free ends and are designated as R, Y and B. The voltage between any line and the neutral point i.e. voltage across each winding is called phase voltage while the voltage between any two lines is called the line voltage.

The currents flowing in the phase are called phase currents and those flowing in the lines are called the line currents. Phase sequence is RYB.

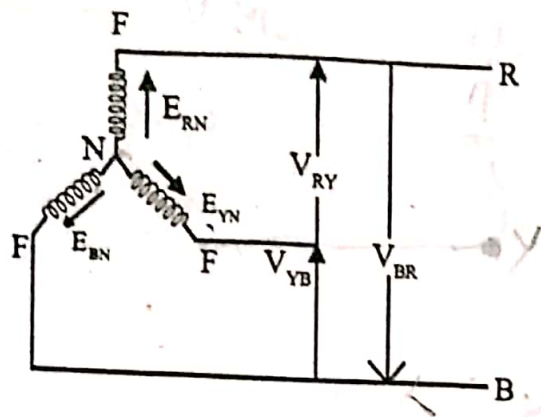

Fig. 4.7 (a)

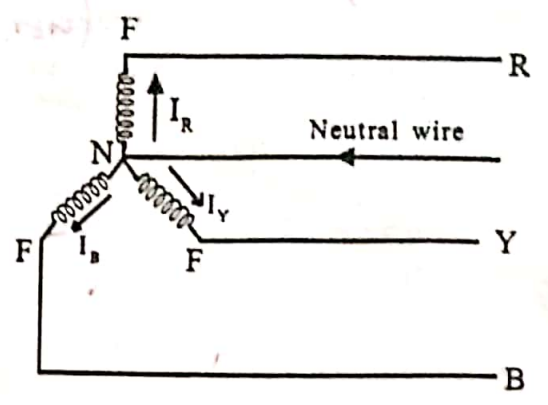

Fig. 4.7 (b)

4.2.1 Relation between line and phase voltages

Figure 4.8 shows a balanced 3 phase Y connected system in which the r.m.s. values of the emfs generated in the three phases are E_{RN} , E_{YN} and E_{BN} . It is clear that the potential difference between any two line terminals i.e the line voltage is the phase difference between the potential of these terminals w.r.t. neutral point i.e

$$\begin{aligned} V_{RY} &= E_{RN} - E_{YN} \\ V_{YB} &= E_{YN} - E_{BN} \\ V_{BR} &= E_{BN} - E_{RN} \end{aligned}$$

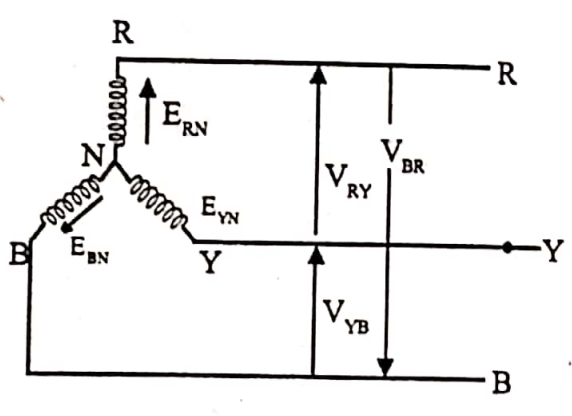

Fig. 4.8

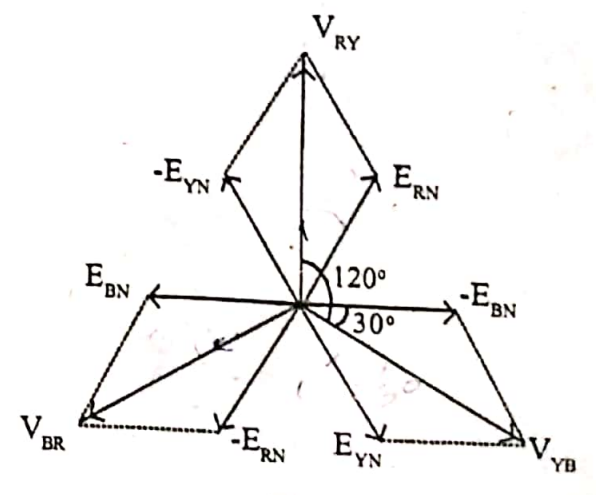

Fig. 4.9

Considering lines R and Y the line voltage V_{RY} is equal to the phasor difference of E_{RN} and E_{YN} . To subtract E_{YN} from E_{RN} reverse the phasor E_{YN} and find its phasor sum with E_{RN} as shown in the phasor diagram. The two phasors E_{RN} and $-E_{YN}$ are equal in magnitude and equal to E_{ph} and 60° apart.

$$\begin{aligned} V_{RY} &= 2E_{ph} \cos 60^\circ/2 = 2E_{ph} \cos 30^\circ \\ &= \sqrt{3} E_{ph} \end{aligned}$$

Similarly

$$\begin{aligned} V_{YB} &= \sqrt{3} E_{ph} \\ V_{BR} &= \sqrt{3} E_{ph} \end{aligned}$$

Hence in a balanced three phase Y connection

1. Line voltage = $\sqrt{3}$ Eph .

All line voltages are equal in magnitude but displaced by 120 degree from one another.

2. Line voltages are 30° ahead of their respective phase voltages.

4.2.2 Relation between line and phase currents

In Y connection each line conductor is connected in series to a separate phase as shown in figure 4.10. Therefore current in a line conductor is the same as that in the phase to which the line conductor is connected

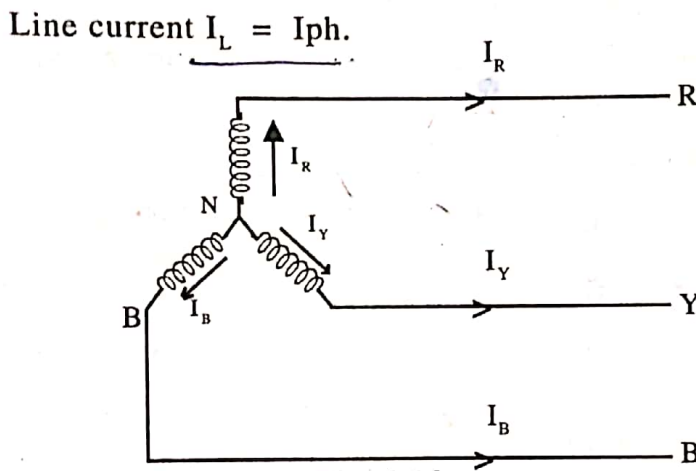

Fig. 4.10

Figure 4.11 shows the phasor diagram for a balanced lagging load, the phase angle being ϕ . Hence in a balanced 3 phase Y connection.

1. Line current $I_L = I_{ph}$.
2. All line currents are equal in magnitude but displaced by 120° from one another.
3. The angle between line currents and the corresponding line voltages is $30 \pm \phi$, '+' if p.f. is lagging and '-' if it is leading.

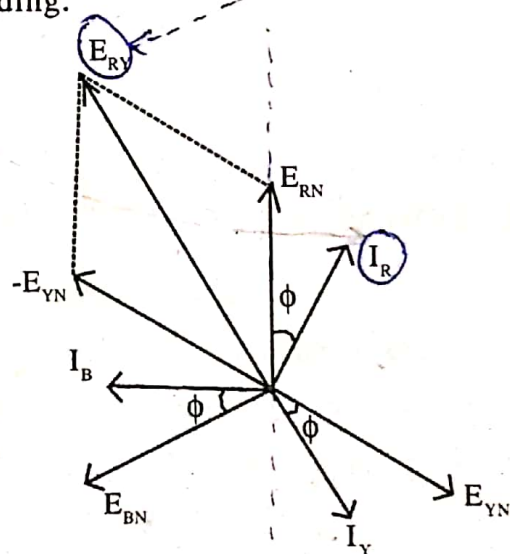

Fig. 4.11

Power

$$\begin{aligned} \text{Total power } P &= 3 \times \text{power in each phase} \\ &= 3 \times E_{ph} \times I_{ph} \times \cos\phi \\ &= 3 E_{ph} I_{ph} \cos\phi \end{aligned}$$

$$\text{For Y connection } E_{ph} = \frac{V_L}{\sqrt{3}} \quad \text{and } I_{ph} = I_L$$

$$P = 3 \frac{V_L}{\sqrt{3}} \times I_L \times \cos\phi$$

$$P = \sqrt{3} V_L I_L \cos\phi$$

$\cos\phi$ is the power factor and ϕ is the phase difference between phase voltage and the phase current.

4.2.3 Points to remember

1. The three phase voltage [ie. E_{RN} , E_{YN} , E_{BN}] are equal in magnitude but displaced 120° from each other. The same is true for line voltages ie. V_{RY} , V_{YB} and V_{BR} . Such a supply system is called balanced supply system.
2. Line voltage = $\sqrt{3}$ x phase voltage. Thus Y connection enables us to use two voltages ie. phase voltage and line voltage.
3. Line current = Phase current
4. For a 3 phase 4 wire star connected supply, the current I_N in the neutral wire is the phasor sum of the three line currents. For a balanced load $I_N = 0$
5. The arrowheads alongside currents or voltages indicate their directions when they are assumed to be positive and not their actual direction at a particular instant. At no instant will all the three line currents flow in the same direction either outwards or inwards. This is expected because the three line currents are displaced 120° from one another. When one is positive, the other two might both be negative or one positive and one negative. Thus at any instant current flows from the alternator through one of the lines to the load and returns through the other two lines or else current flows from the alternator through two lines and returns by means of third.

4.3 DELTA OR MESH CONNECTION

In this method of interconnection the dissimilar ends of the three phase windings are joined together ie. finishing end of one phase is connected to the starting end of the other phase and so on, to obtain mesh or delta as shown in figure 3.29.

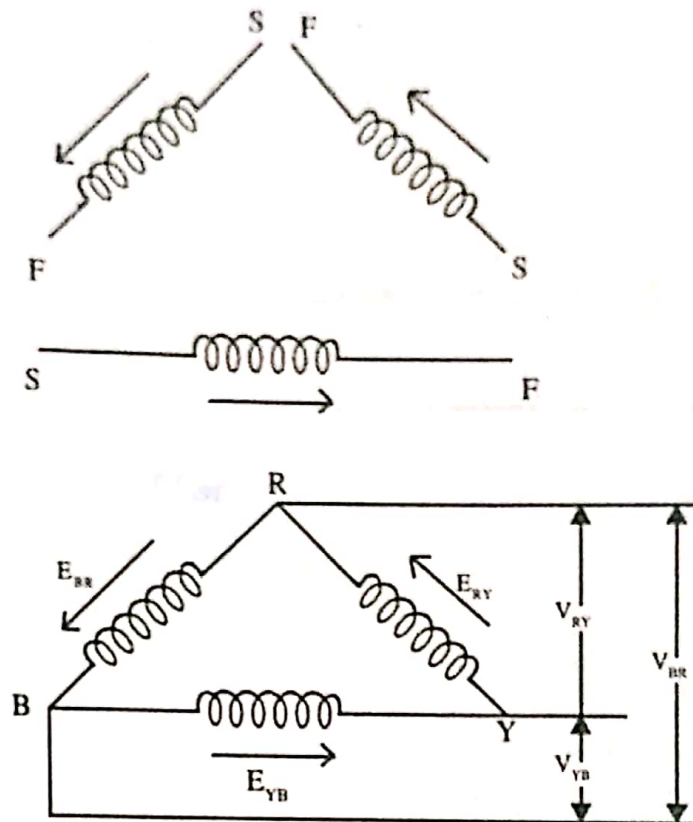

Fig. 4.12

It may appear as if the three phases are short circuited on themselves. But that is not the case. The finishing end of one phase is connected to the starting end of the other phase so that the resultant voltage around the mesh is the phasor sum of the three phase voltages. Since the three phase voltages are equal in magnitude and displaced 120° from one another, their phasor sum is zero. Therefore no current can flow around the mesh when the terminals are open

4.3.1 Relation between line and phase voltages

Since the system is balanced the three phase voltages are equal in magnitude but displaced by 120° from each other. From Figure 2.31 it is clear that only one phase winding is included between any pair of lines. Hence in delta connection $V_L = V_{ph}$.

4.3.2 Relation between line and phase currents

Since the system is balanced, the three phase currents I_R , I_Y and I_B are equal in magnitude and displaced from each other by 120° . An examination of current shows that current in any line is equal to the phasor difference of the currents in the two phasors attached to that line.

Current $I_L = I_R - I_B$. The current in the line is the phasor difference of I_R and I_B .

$$\begin{aligned} I_L = I_1 &= I_R - I_B = 2 I_{ph} \cos 60^\circ/2 \\ &= 2 I_{ph} \cos 30^\circ = \sqrt{3} I_{ph} \end{aligned}$$

The three line currents I_1 , I_2 and I_3 are equal in magnitude each being equal to $\sqrt{3} I_{ph}$.

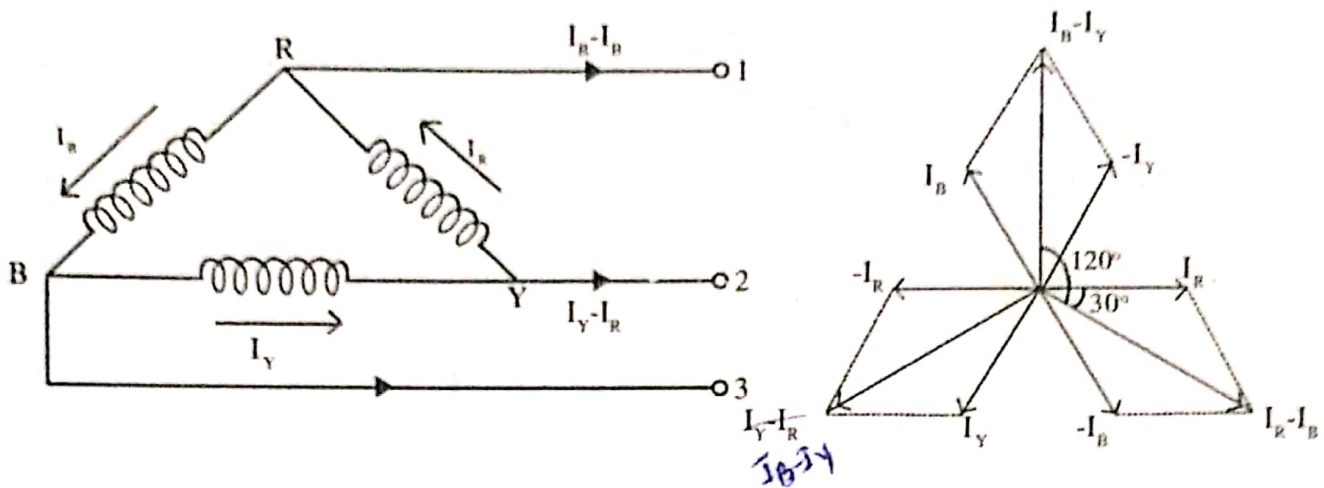

Fig.4.13

Hence in balanced Δ connection

1. Line current $I_L = \sqrt{3} I_{ph}$.
2. All line currents are equal in magnitude but displaced by 120° from one another.
3. Line currents are 30° behind their respective phase currents.

4.4. ADVANTAGES OF STAR AND DELTA CONNECTED SYSTEMS

In three phase system, the alternators may be star or delta connected. Also three phase loads may be star or delta connected. Following are the advantages:

4.4.1. Star Connection

1. In star connection $V_{ph} = V_L / \sqrt{3}$. Since the induced emf in the phase winding of an alternator is directly proportional to the number of turns, a star connected alternator will require lesser number of turns than a delta connected alternator for the same line voltage.
2. For the same line voltage, a star connected alternator will require lesser amount of insulation. Due to the above reasons, three phase alternators are generally star connected.
3. With star connection, it is possible to use two levels of voltages, that is phase voltage and line voltage.
4. In star connection, neutral point may be earthed. Earthing of neutral permits the use of relays.

4.4.2. Delta Connection

1. This type of connection is most suitable for rotary converters.
2. Most of the three phase induction motors are delta connected.
3. Three phase loads are generally delta connected. This is because of the flexibility with which load may be added or removed on a single phase which is more difficult with three phase star connected load.

4.5. EXAMPLES

1. A balanced star connected load of impedance $(6+j8)$ ohms per phase is connected to a three phase 230V , 50Hz . supply. Find the line current and power absorbed by each phase.

Solution

$$Z_{ph} = \sqrt{6^2 + 8^2} = 10 \Omega$$

$$V_{ph} = \frac{V_L}{\sqrt{3}} = \frac{230}{\sqrt{3}} = 133 \text{ V}$$

$$\cos\phi = \frac{R}{Z} = \frac{6}{10} = 0.6 \text{ lag}$$

$$I_{ph} = \frac{V_{ph}}{Z_{ph}} = \frac{133}{10} = 13.3 \text{ A}$$

$$I_L = I_{ph} = 13.3 \text{ A}$$

Power absorbed per phase

$$= V_{ph} I_{ph} \cos\phi_A$$

$$= 133 \times 13.3 \times 0.6 = 1061 \text{ W}$$

2. The load to a 3 phase supply comprises of three similar coils connected in star. The line currents are 25 A and kVA and kW inputs are 20 and 11 respectively. Find (1) the phase and line voltage (2) the kVAR input (3) resistance and reactance of each coil.

Solution

$$I_L = I_{ph} = 25 \text{ A}$$

$$\text{Apparent power} = 20 \text{ kVA}$$

$$\text{kVA} = 3 \times V_{ph} \times I_{ph}$$

$$1. \quad V_{ph} = \frac{20 \times 10^3}{3 \times 25} = 267 \text{ V}$$

$$V_L = \sqrt{3} V_{ph} = \sqrt{3} \times 267 = 462 \text{ V}$$

$$2. \quad \text{kVAR} = \sqrt{\text{kVA}^2 - \text{kW}^2} = \sqrt{20^2 - 11^2} = 16.7 \text{ kVAR}$$

$$3. \quad \text{p.f.} = \cos\phi = \frac{\text{kW}}{\text{kVA}} = \frac{11}{20}$$

$$Z_{\text{ph}} = \frac{V_{\text{ph}}}{I_{\text{ph}}} = \frac{267}{25} = 10.68 \Omega$$

$$R_{\text{ph}} = Z \cos\phi = 10.68 \times \frac{11}{20} = 5.87 \Omega$$

$$X_{\text{ph}} = \sqrt{10.68^2 - 5.87^2} = 8.92 \Omega$$

- 3 Calculate the current flowing in each line and in each phase of a 3 phase delta connected motor developing an output of 186.5 kW at 2.3 kV at a p.f. of 0.75 and efficiency 0.85

Solution

$$\text{Output} = 186.5 \times 10^3 \text{ W}$$

$$\text{Input} = \text{Output}/\text{Efficiency} = 186.5 \times 10^3 / 0.85$$

$$= 219.412 \text{ kW}$$

$$\sqrt{3} V_L I_L \cos\phi = \text{Input Power}$$

$$I_L = \text{Power input} / \sqrt{3} V_L \cos\phi$$

$$= 219412 / \sqrt{3} \times 2300 \times 0.75$$

$$= 73.44 \text{ A}$$

$$I_{\text{ph}} = I_L / \sqrt{3} = 42.4 \text{ A}$$

- 4 Show that the power consumed by three identical single phase loads connected in a delta is three times the power consumed by three identical single phase loads connected in a star.